

Regolatore di processo  
Dual loop, Multi-ingresso,  
Multi-uscite, Multi-funzioni

Serie **QD**



Dual Loop Process Controller  
Multi-input, Multi-output  
Multi-functions

Series **QD**

ISTRUZIONI PER L'USO  
INSTRUCTION MANUAL  
M.I.U. QD - 1/96.05  
Cod. J30 - 304 - 1AQD-IE



**ASCON spa**

<b>1</b>	IDENTIFICATION OF MODEL	page	2
<b>2</b>	DIMENSIONS AND INSTALLATION	page	3
<b>3</b>	ELECTRICAL WIRING	page	4
<b>4</b>	KEYS AND DISPLAYS FUNCTIONS	page	12
<b>5</b>	CONFIGURATION	page	14
<b>6</b>	PROGRAMMING PROCEDURE	page	20
	1 Standard Loop	page	21
	1 Cascade Loop	page	25
	1 Ratio Loop	page	29
	2 Independent Loops	page	33
	Parameter description	page	37
<b>7</b>	OPERATING INSTRUCTIONS	see enclosed leaflet	
<b>8</b>	TECHNICAL DATA	pag.	42
<b>9</b>	SERIAL COMMUNICATIONS (See MIU-CS)	separately supplied	

E

**READING INSTRUCTION**

To better read and understand this manual please note the following:

**Electrical wiring**

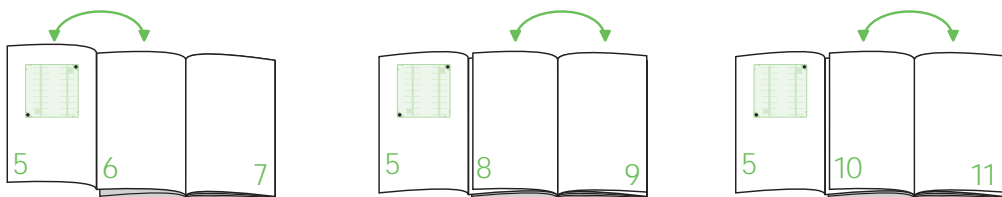

**Configuration**

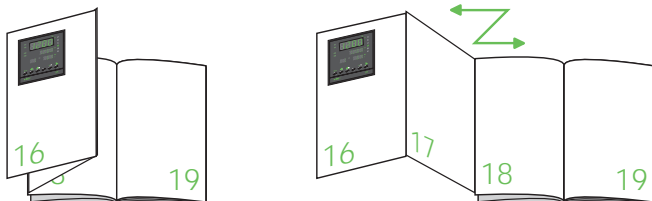

**Programming**

1 Standard Loop

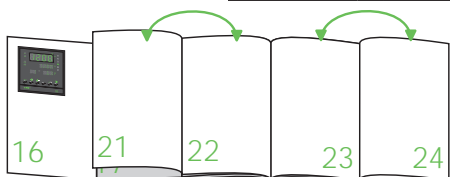

1 Cascade Loop

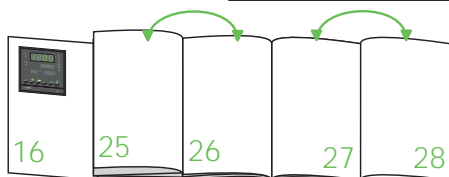

1 Ratio Loop

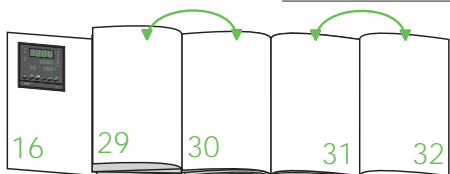

2 Independent Loops

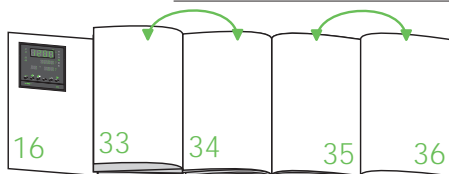

Thank you for choosing an ASCON controller.

The dual controller of the QD series can be configured as 1 cascade or ratio Loop or 2 independent loops. They are universal, very powerful but simple to use.

They are fitted with AUTO-TUNE, as auxiliary for system start-up, and serial communications for introduction into a distributed control network.

They are complete because all possible variables are always present.

Configuration of the instrument permits determination of the operating mode according to the required application.

## 1.1 Identification of model

Model code : QD **A** **B** **C** **0**



Model code:	QD	A	B	C	0		
Power supply						<b>Power supply</b>	<b>A</b>
						100...240V 50/60 Hz	3
						16...28V 50/60 Hz and 20...30V dc	5
Serial communications RS485						<b>Serial communications (option)</b>	<b>B</b>
						None	0
						RS485 Modbus - Jbus	3
Auxiliary analog output Y6						<b>Y6 auxiliary output (option)</b>	<b>C</b>
						None	0
						0/4...20mA, 0/1...5V, 0...10V	1

## 2.1 Overall dimensions

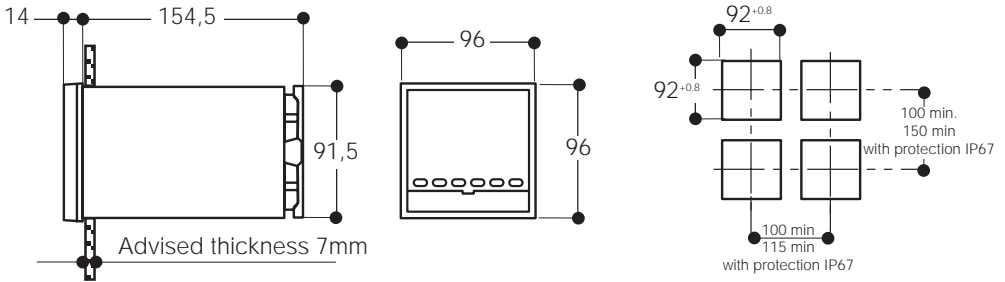

## 2.2 Panel installation

A •

Panel fitting

- Install away from:
- heat sources
  - corrosive gases
  - dusty environments



ENVIROMENT:

Temperature: 0...50 °C

Humidity : 30...85UR%

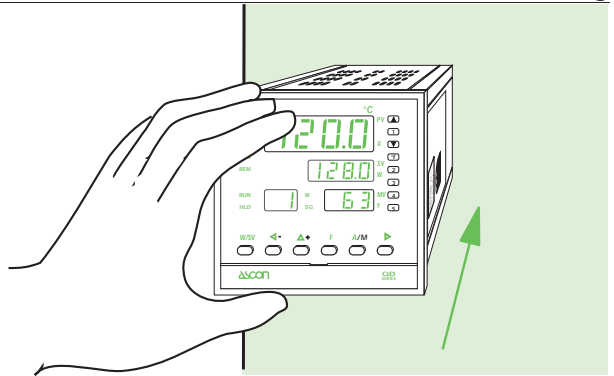

E

B •

Fixing with clamps

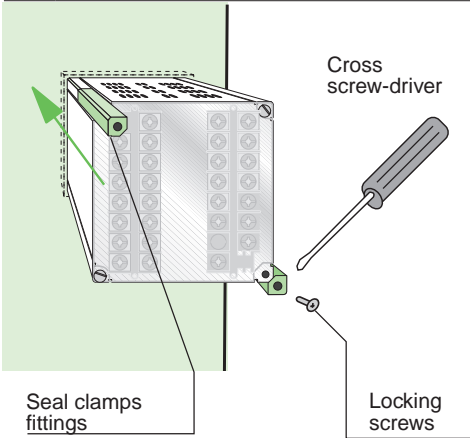

C • plate for engineering units

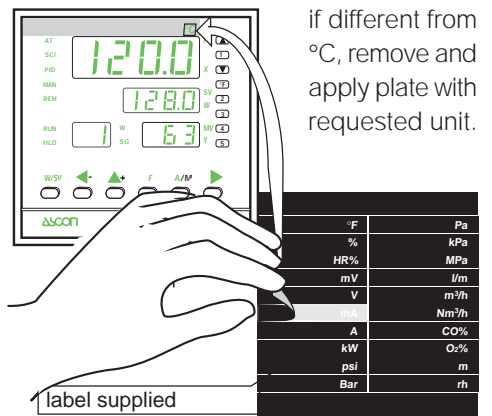

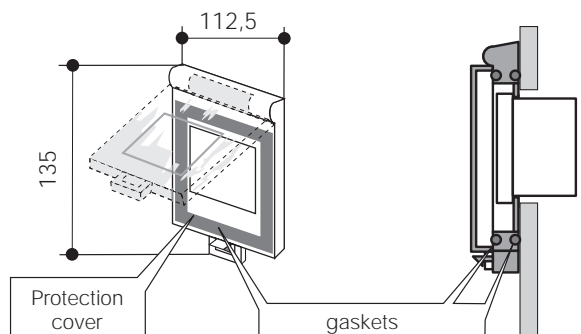

## 2.3 Front protection IP67

mod. F10-435-2A101



A •

Terminal board

-  24 screw terminals M3.5
-  6 gilded terminals for input signals

Wiring protection plate

Cold joint compensation thermometer

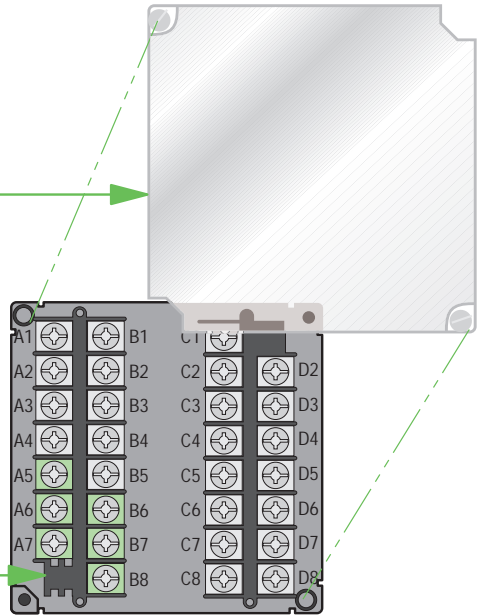

E

B •

Effecting the connections

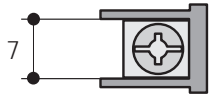

cable section  
0,25÷2,5 mm<sup>2</sup>  
AWG 22÷14

Preferential

with eyelet terminals

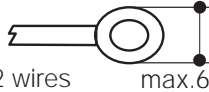

with fork terminals



### 3.1 Precautions and advised conductor course

Although this controller is designed to resist the heaviest disturbances present in industrial environments (as per CE mark), it is advised to keep to the following precautions:

A. Precautions

B. Advised conductor course



**Single out**  
supply line  
from power line

**Keep away** from  
teleruptors,  
electromagnetic  
contactors and  
powerful motors

**Keep away** from  
power groups,  
in particular if  
with phase control

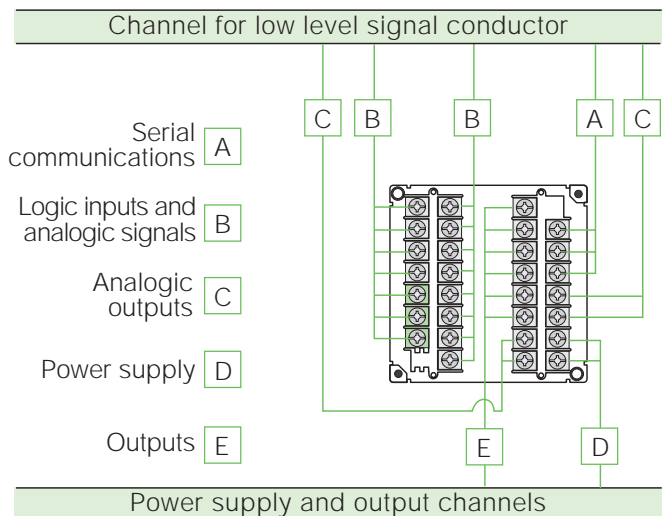

Wiring diagram

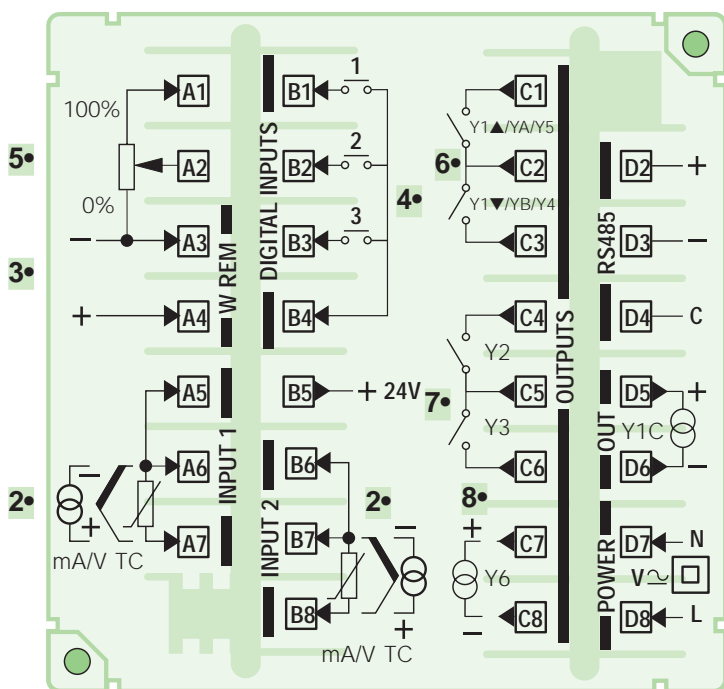

Relay outputs, combined to the terminals C1/C2 and C2/C3, can be configured as auxiliary output Y4 and Y5 (alarms) only if they are not used as main control output.

Single power supply

switching type with double isolation  
 Standard:  
 100...240Vac  
 -15 +10% (250 Vac max)  
 or:  
 24Vac - 24Vdc -15 +10%  
 Absorbed power 5 VA max

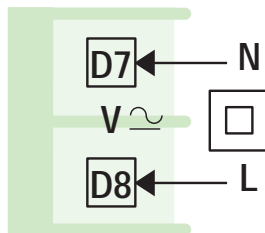

"X1 or X2" measurement inputs

**Note:** INPUT 1 and INPUT 2 can be configured with different types of signal (e.g. Input 1 thermocouple and Input 2 mA). The input shown herebelow are only indicative.

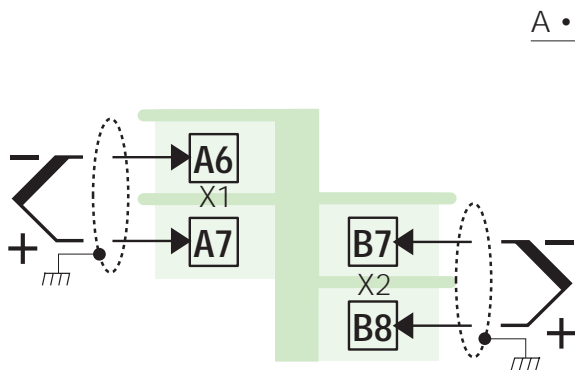

A • For Thermocouples  
 J-L-T-K-S-R-B-N-E-W

- Respect polarities
- For eventual extensions, use a compensated cable suitable for the type of used thermocouple
- The eventual screen is well earthed at only one end

2 • "X1 or X2" measurement input (continued)

**Note:** INPUT 1 and INPUT 2 can be configured with different types of signal (e.g. Input 1 thermocouple and Input 2 mA). The input shown herebelow are only indicative.

For 2 wires connection a jumper among A5 and A6 and/or B6 and B7 terminals must be done.

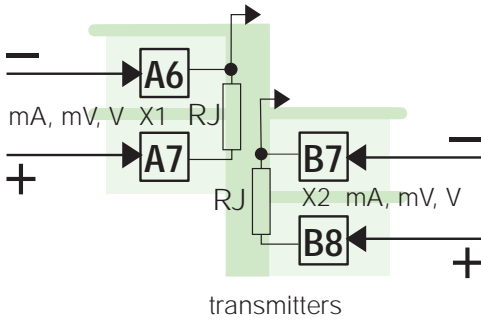
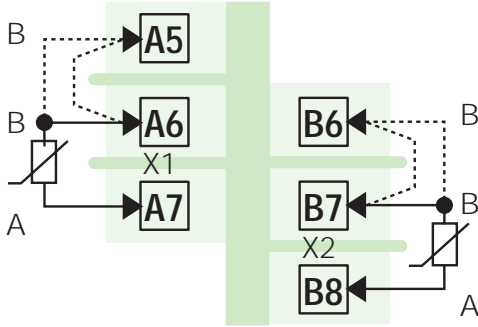

B • For RTD Pt100

- For 3-wires connection, use cables of same section (min. 1mm<sup>2</sup>)  
Line 20Ω max. for wire
- For 3-wires connection, use cables of adequate section (min.1,5mm<sup>2</sup>)  
**Note:** with a 15m probe-controller distance and a 1,5mm<sup>2</sup> section cable, the error is about 1°C.

C • Continuous mA, Volt

- Internal R<sub>j</sub> = 30Ω per mA
- Internal R<sub>j</sub> = 10MΩ per mV
- Internal R<sub>j</sub> = 10KΩ per Volt

C.1 • For 2 wires transmitter

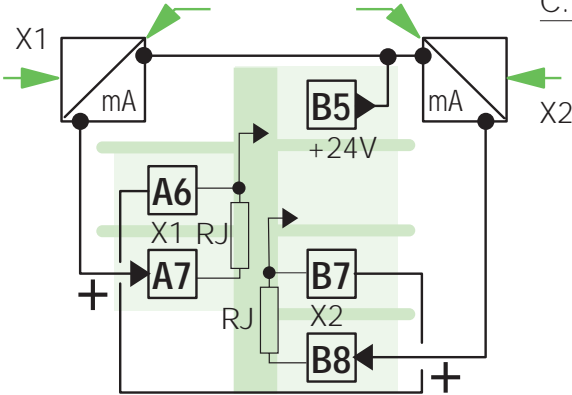

- auxiliary power supply for transmitter
- 24 Vdc ±10%
- 30mA max

C.2 • For 3 or 4 wires transmitter

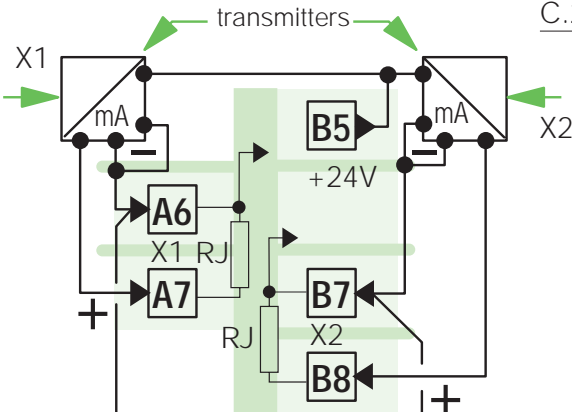

- auxiliary power supply for transmitter
- 24 Vdc ±10%
- 30mA max

3 • Remote Set point input

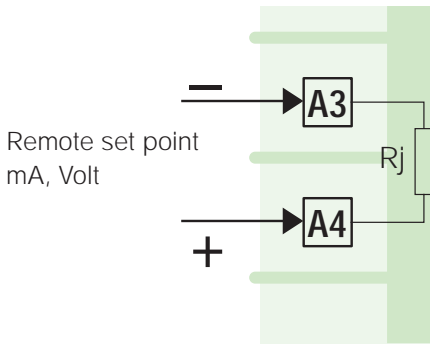

In current  
0/4...20mA  
Internal  $R_j = 30\Omega$

In voltage  
1...5V, 0...5V, 0...10V  
Internal  $R_j = 300\text{K}\Omega$



NOT galvanically isolated

4 • Logic inputs

When the external logic input is ON (maintained closed contact), the relevant function is operating.

When the external logic input is OFF (maintained opened contact), the relevant function is not operating.  
(see page 19)

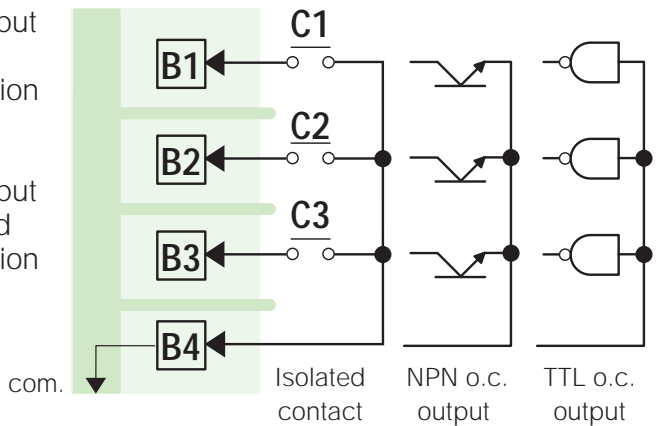

5 • Input potentiometer position (servomotors)

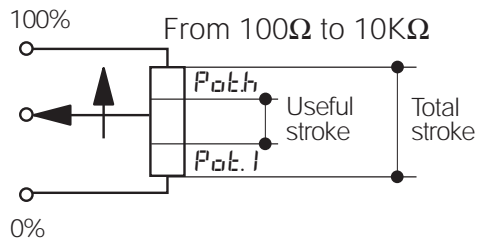
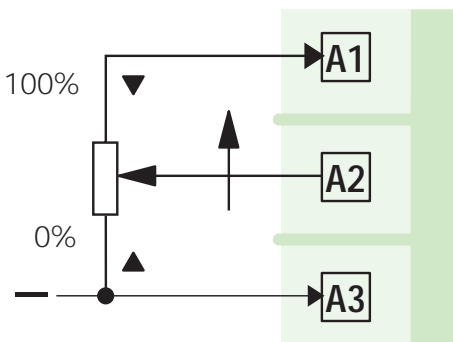



**6.0• Single output with relay**  
configuration T=0

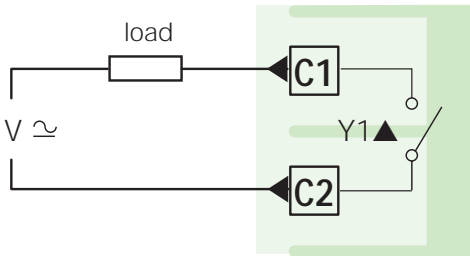

One contact NA

**6.1• Output single logic**  
configuration T=1

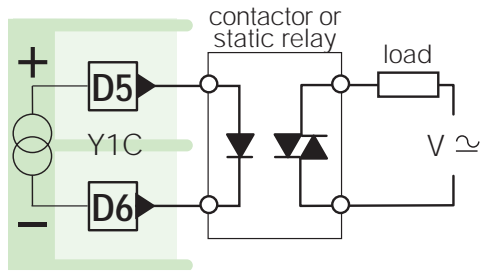

Output 0...22Vdc ±20% (20mA max.)  
galvanically isolated

**6.2• Continuous single output**  
configuration T=2

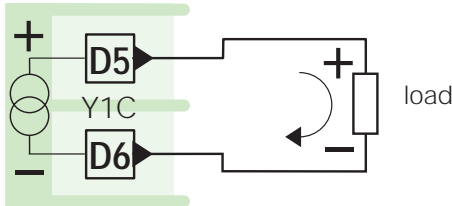

galvanically isolated  
500Vac/1min  
750Ω/15V max in current  
500Ω/20mA max in voltage

**6.3• Output for servomotors**  
configuration T=3

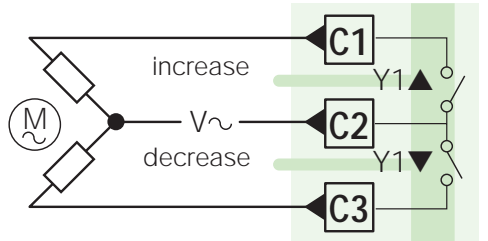

Three position with two interlocked contacts (increase, stop, decrease)

**6.4• Relay / relay dual action output**  
configuration T=4

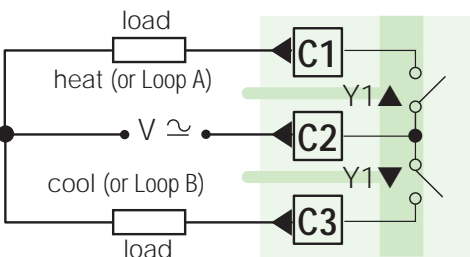

2 contacts NA

**6.5• Relay / logic dual action output**  
configuration T=5

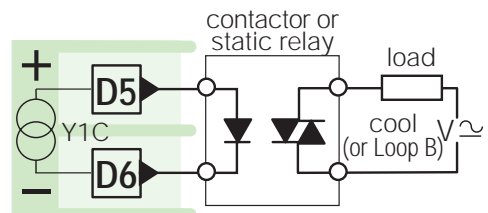
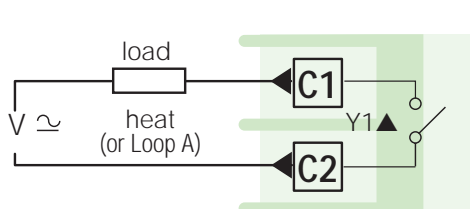

**6.6• Relay / continuous dual action output**  
configuration T=5

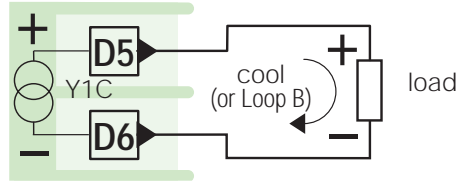
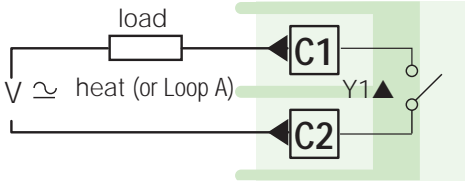

**6.7• Logic / relay dual action output**  
configuration T=7

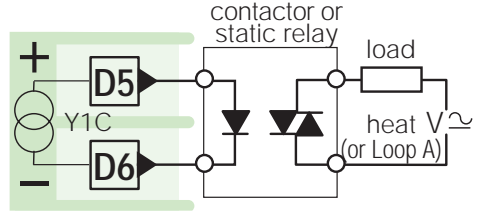
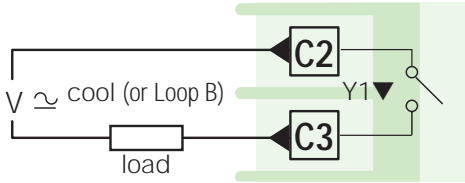

**6.8• Logic / continuous dual action output**  
configuration T=8

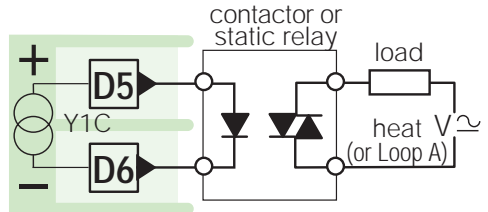
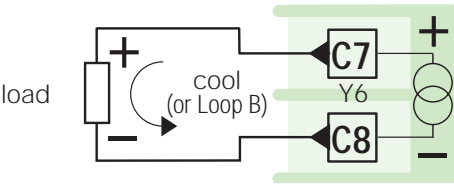

**6.9• Continuous / relay dual action output**  
configuration T=9

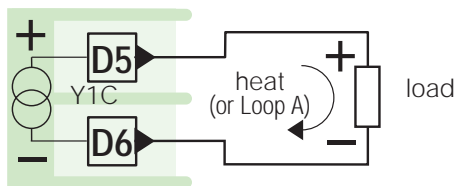
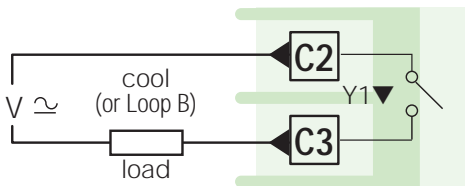

**6.10• Continuous / logic dual action output**  
configuration T=10

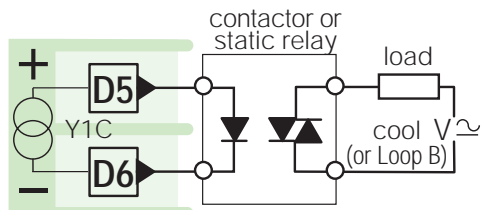
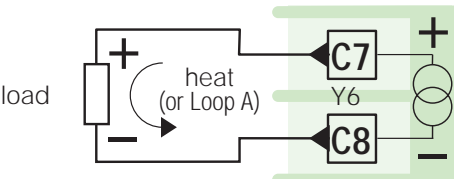

**6.11• Continuous / continuous dual action output**  
configuration T= 11

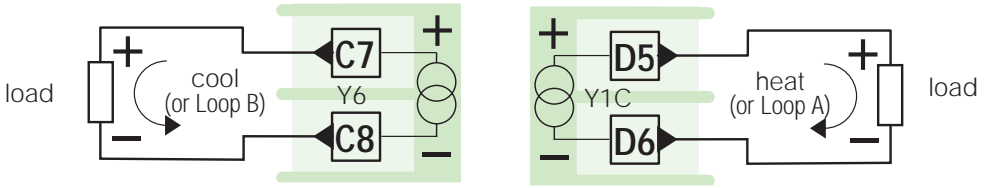

**6.12 Servomotor/Logic dual action output**  
configuration T= 12

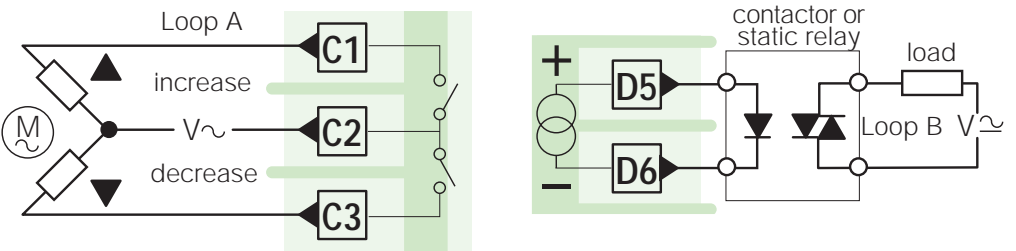

**6.13 Servomotor/continuous dual action output**  
configuration T= 13

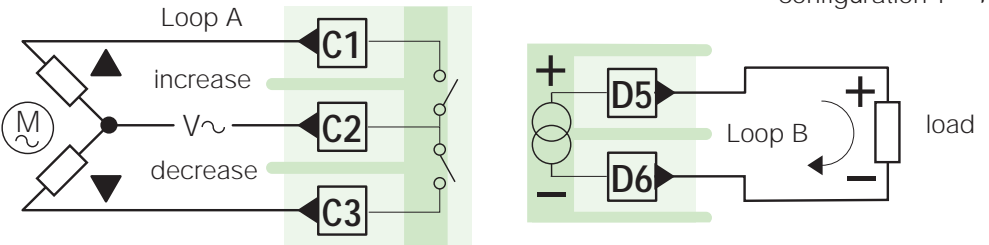

7• (6•)

**Auxiliary output Y2-Y3**

Configurable to work as auxiliary output of Loop A or Loop B  
see page 19

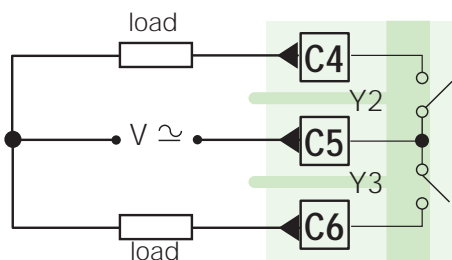

2 N.O. relay outputs

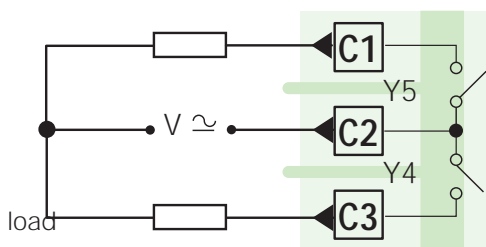

2 N.O. relay outputs



The 2 N.O. relay outputs can be used as Y4 and Y5 auxiliary outputs, only if they are not used before as main control relay outputs.

**E**

8•

**Retrasmission output Y6 (option)**

see page 19

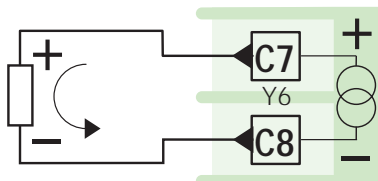

galvanically isolated  
500Vac/1min  
750Ω/15V max in current  
500Ω/20mA max in voltage

9•

**Serial communications (option)**

Consult direction for use  
"SERIAL  
COMMUNICATIONS  
SUPPLEMENT"

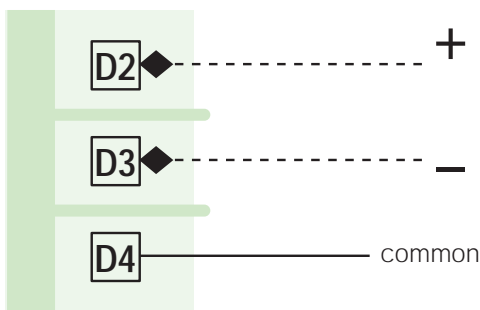

Measured value X (PV),  
engineering units;  
Over range indication **8888**

Under range indication **8888**  
Parameter values indication during  
the programming phase.

Flashes with  
signal in  
transit

- Auto-tune in course → **AT**
- Active serial com. → **SCI**
- 2<sup>nd</sup> PID algorithym is active → **PDI**
- Manual operation → **MAN**
- Active Remote Set → **REM**
- Active memorized Set → **W**

OFF during normal  
conditions;  
For operating condition  
message.  
Please see herebelow  
table

Auxiliary  
display

In manual  
operation,  
decrement  
the value of

Set point menu

In manual  
operation,  
increment  
the value of  
output

Select digit

Increase digit

Withdrawal  
screw

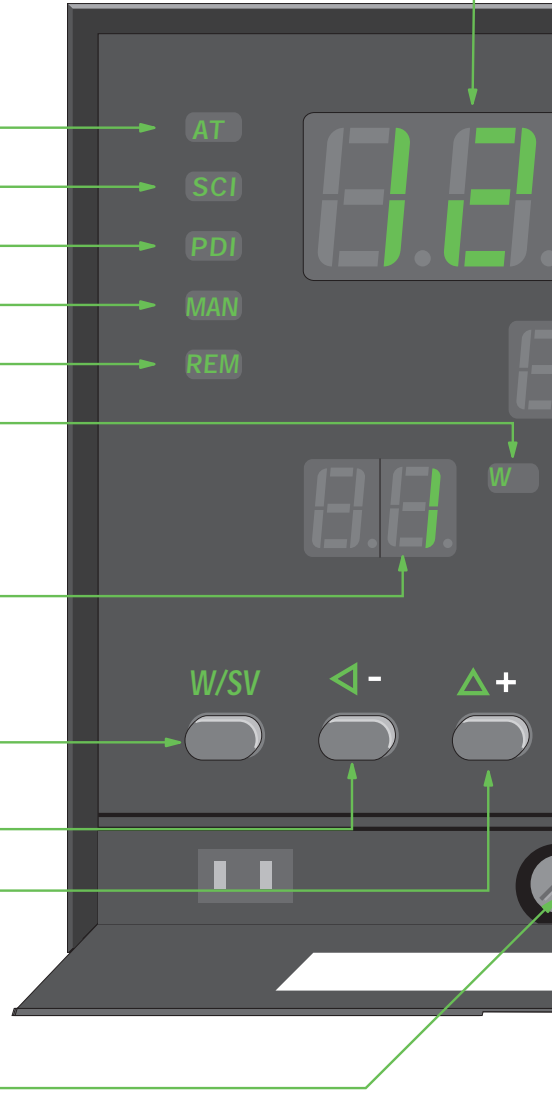

Message	Instrument operatin condition
<b>1,2,3</b>	One of three memorized Set point is operating.
<b>a.</b>	The main displays show the variables of loop A
<b>b.</b>	The main displays show the variables of loop B
<b>MA</b>	The main displays show the variables of Master loop (cascade)
<b>SL</b>	The main displays show the variables of Slave loop (cascade)
<b>EU</b>	X/PV and W/SV displays show X1 and X2 variables in eng. units
<b>C</b>	Computer set point is operating
<b>Yr</b>	One of three logic inputs is forcing Y1 equal to Remote Set Point
<b>YP</b>	One of three logic inputs is forcing Y1 equal to Forcing output value

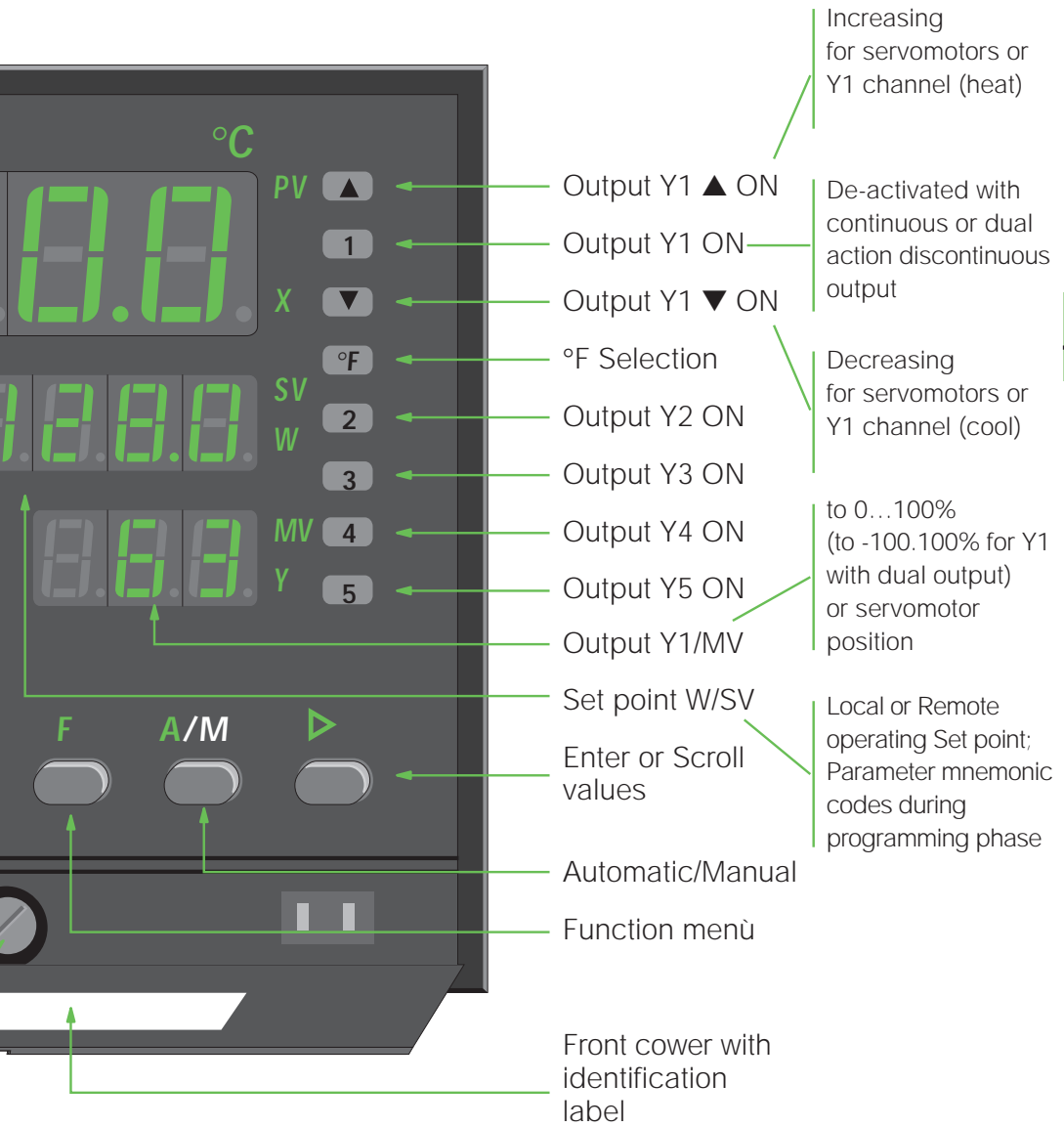

E

When the mounting and wiring are completed, the instrument shall be configured and then programmed. The controller is of the universal type, this means that all the functions are available on the instrument, configuration and programming allow to select and adjust the desired functions.

**5.1• Configuration Access**



Configuration is essential for the correct operation of the controller. Proceed with care.

It is possible enter in configuration phase by two different ways.

**5.1.2• Not configured instrument (1<sup>st</sup> configuration)**

When powered, the instrument is in the stand-by mode, all the outputs are not operating.

The displays show permanently



**5.1.3• Configured instrument (configuration modify)**

When powered, the instrument automatically checks if the configuration is correct. For 5 seconds all the outputs are not operating. After 5 seconds, and if the configuration is correct, the instrument is automatically started.

The instrument identification E2G is displayed for 5 seconds

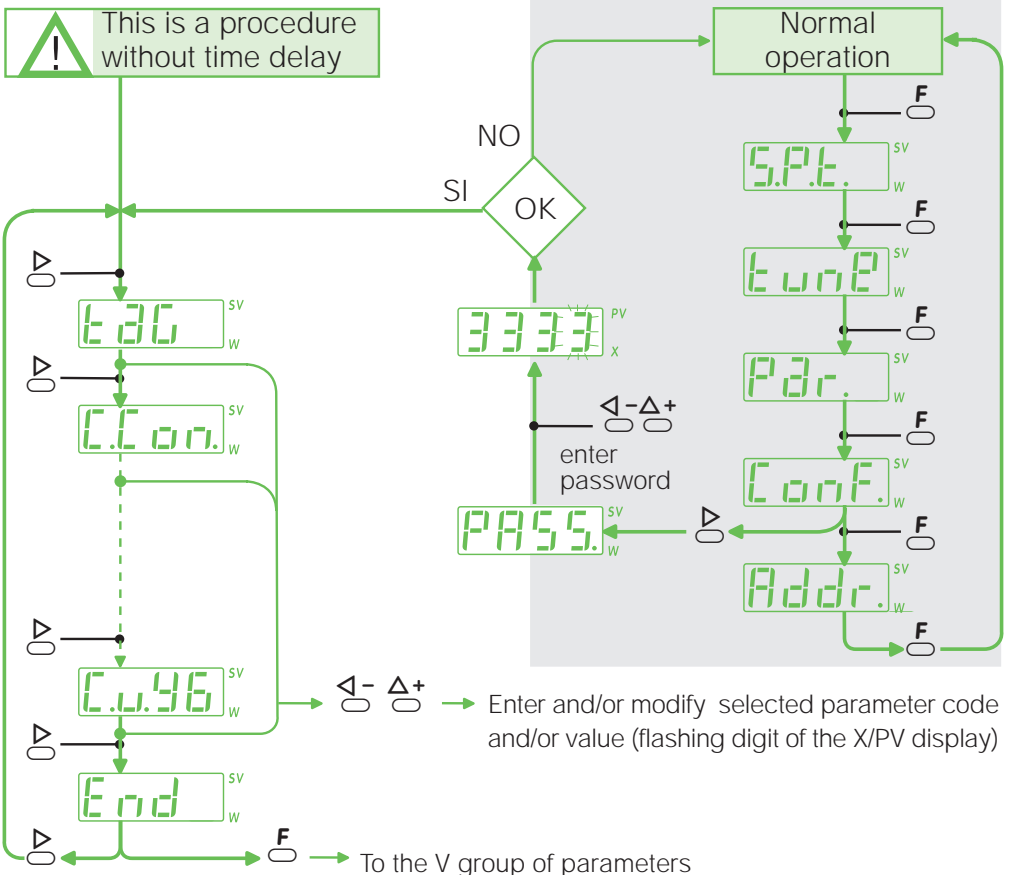

## A • Instrument Withdrawal

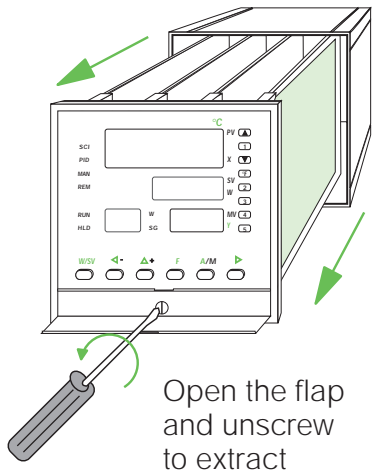

Open the flap  
and unscrew  
to extract

## B • Unhook the paper support

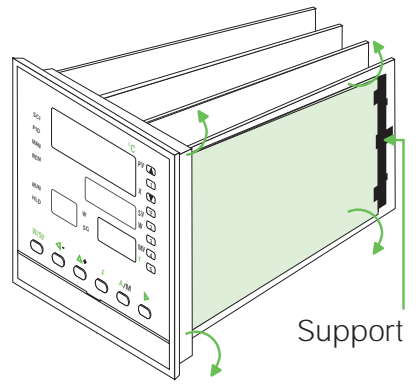

Support

Left the support, unhook  
and unthread the paper

## C • Share paper

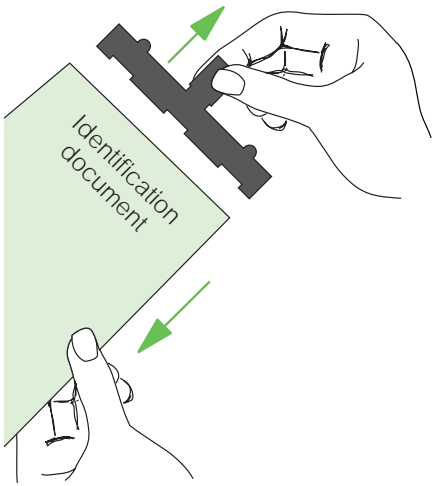

## D • Write table

Open paper

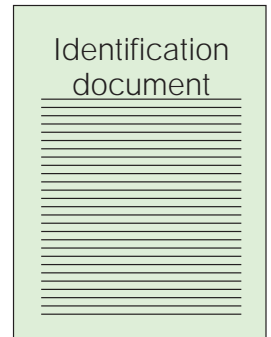
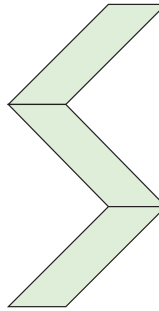

Fold the paper and  
connect to the support

## E • Insert paper

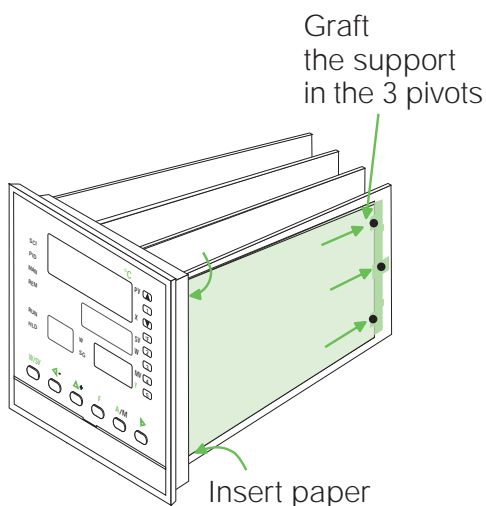

Graft  
the support  
in the 3 pivots

Insert paper

## F • Instrument insert

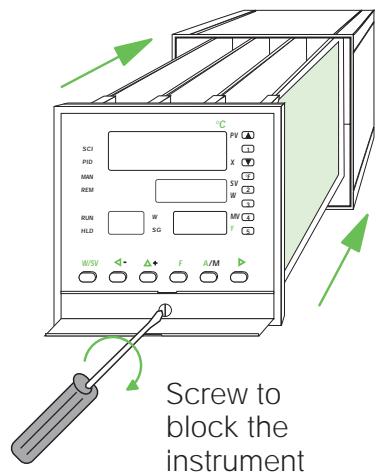

Screw to  
block the  
instrument



# KEYS AND DISPLAYS FUNCTIONS

Measure during normal operation

Selected value/code during programming phase

Set Point during normal operation

Mnemonic code during programming phase

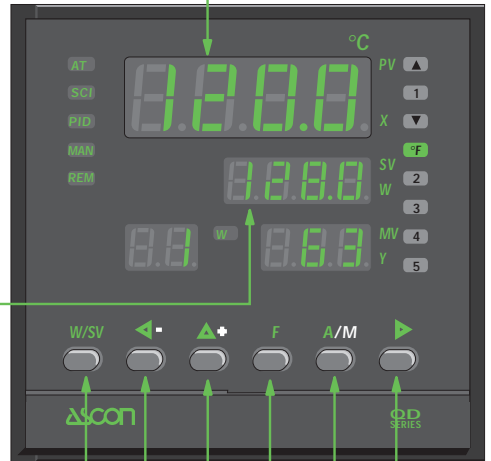

E

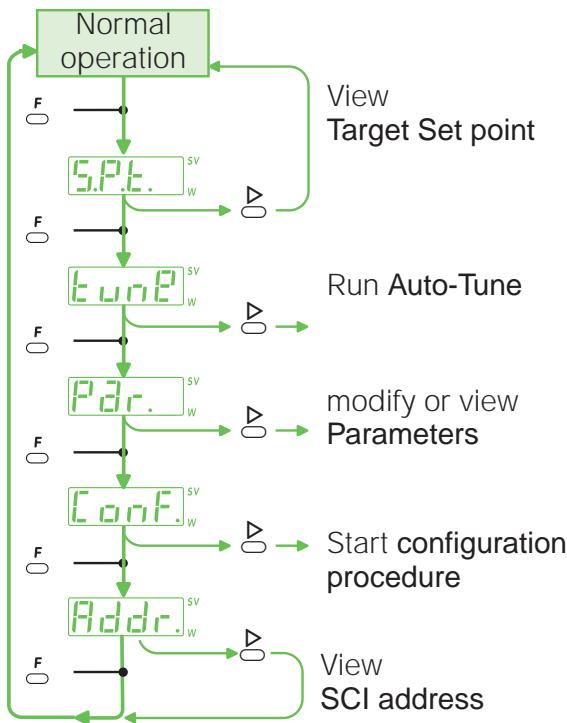

Enter or scroll values

Automatic/Manual

Access to function menu

Increasing digit

Select digit

Access to Set point menu

## These notes are referred to the table at page 17

**Attention:** codes, not coherent with the previously selected ones, if entered, are not accepted. Not admitted codes are also not accepted.

When the selected value is higher than the admitted value, the X/PV display shows:



When the selected value is lower than the admitted value, the X/PV display shows:



**For an easy and quick subsequent identification/modification** of the controller operating characteristics, it is suggested (as soon as the configuration is completed), to fill the "Identification document" located inside the instrument with the configuration codes/values. (see page 15)

## 5.2

## Configuration phase































procedure without time delay



Before to enter the configuration codes and parameter values given in the pages 18 and 19, it is suggested to carefully fill the table given herebelow with the selected codes/values.

All configuration codes/values affect the following ones, due to this, entering of the configuration codes/values must be done in accordance with the sequence given herebelow.

When the configuration phase is started, the first configuration parameter is displayed. By pressing the  key, all the configuration parameters are scrolled in accordance with the sequence given in the following table.

 Parameter mnem. code (display W/SV)	parameter description	Entered Code and/or value (display X/PV)	Ref.
 →  Identification tag number			<b>A</b>
→  Algorithm and control action			<b>B</b>
→  Set point type			<b>C</b>
→  X1 Input type and scale range			<b>D</b>
→  X1 °C, °F e K selection			<b>E</b>
→  X1 Cool joint compensation			<b>F</b>
→  X1 Decimal point for linear scales			<b>G</b>
→  X1 Scale beginning value for linear scales			<b>H</b>
→  X1 End scale value for linear scales			<b>K</b>
→  X2 Input type and scale range			<b>I</b>
→  X2 °C, °F e K selection			<b>J</b>
→  X2 Cool joint compensation			<b>L</b>
→  X2 Decimal point for linear scales			<b>M</b>
→  X2 Scale beginning value for linear scales			<b>N</b>
→  X2 End scale value for linear scales			<b>O</b>
→  1 Input Logic function			<b>P</b>
→  2 Input Logic function			<b>Q</b>
→  3 Input Logic function			<b>R</b>
→  Remote Set point input range			<b>S</b>
→  Y1 control output type			<b>T</b>
→  Y1 output range			<b>U</b>
→  Y2 alarm type			<b>V</b>
→  Y3 alarm type			<b>W</b>
→  Y4 alarm type			<b>X</b>
→  Y5 alarm type			<b>Y</b>
→  Y6 2 <sup>nd</sup> analog output (retransmission) type			<b>Z</b>
→  Y6 output range			<b>*</b>
 →  End of configuration			

 → To the V group of parameters

The configuration codes/parameter values shown with **grey background**, appear, or do not appear, depending upon the previously selected ones. (see notes page 18 & 19)

**E36**<sub>w</sub><sup>SV</sup>**Identification code** **A**

Selectable range 0000..9999

Freely selectable tag number (in accordance to the customer service assignment).

When the already configured controller is powered, the tag number is shown for 5 seconds on the X/PV display.

**CCon**<sub>w</sub><sup>SV</sup>**Algorithm and control action** **B**

On - Off	Reverse	0
	Direct	1
P.I.D.	Reverse	2
	Direct	3
double P.I.D.	Reverse	4
	Direct	5
Cascade P.I.D.	Rev./Rev.	6
	Dir./Rev.	7
	Rev./Dir.	8
	Dir./Dir.	9
	Rev./Rev.	10
Double Cascade P.I.D.	Dir./Rev.	11
	Rev./Dir.	12
Direct ratio P.I.D.	Rev./Dir.	13
	Dir./Dir.	14
Reverse ratio P.I.D.	Reverse	15
	Direct	16
2 Indip. Loops P.I.D.	Rev./Rev.	17
	Dir./Rev.	18
	Rev./Dir.	19
	Dir./Dir.	20
	Dir./Dir.	21

Press these keys to select digits, to modify values and enter parameter code/value, codes and values are automatically accepted after 5 seconds.

**C.5P**<sub>w</sub><sup>SV</sup>**Set point type** **C**

Only Local	0
Local and 3 memorized	1
Only Remote	2
Local and Remote	3
Local and Local + Remote	4

**C.1n.1**<sub>w</sub><sup>SV</sup> **C.1n.2**<sub>w</sub><sup>SV</sup>**Input type and scale range** **D-1**

RTD <b>Pt100 Ω</b> IEC 751	-200...600°C	
	-328...1112°F	0
	73...873 K	
	-99.9...300.0°C	
Thermocouple <b>J</b> FeCu45%Ni IEC584	-99.9...572.0°F	1
	173.3...573.2 K	
Thermocouple <b>L</b> FeConst. DIN 43710	0...600°C	
	32...1112°F	2
	273...873 K	
Thermocouple <b>T</b> Cu CuNi IEC 584	0...600°C	
	32...1112°F	3
Thermocouple <b>K</b> Cromel-Alumel IEC 584	273...873 K	
	-200...400°C	
Thermocouple <b>S</b> Pt10%Rh-Pt IEC 584	-328...752°F	4
	73...673 K	
Thermocouple <b>R</b> Pt13%Rh-Pt IEC 584	0...1200°C	
	32...2192°F	5
Thermocouple <b>B</b> Pt30% Rh-Pt6%Rh IEC 584	273...1473 K	
	0...1600°C	
Thermocouple <b>N</b> Nicrosil-Nisil IEC 584	32...2912°F	6
	273...1873 K	
Thermocouple <b>E</b> Ni-NiMo18% IEC 584	0...1600°C	
	32...2912°F	7
Thermocouple <b>W</b> W3%Re-W25%Re IEC 584	273...1873 K	
	400...1800°C	
Linear scales	752...3272°F	8
	673...2073 K	
Linear scales with square root extraction	0...1200°C	
	32...2192°F	9
	273...1473 K	
	0...1100°C	
	32...2012°F	10
	273...1373 K	
	0...2000°C	
	32...3632°F	11
	273...2273 K	
	4...20 mA	12
	0...20 mA	13
	0...50 mV	14
	0...200 mV	15
	0...1 V	16
	1...5 V	17
	0...5 V	18
	0...10 V	19
	4...20 mA	20
	0...20 mA	21
	0...50 mV	22
	0...200 mV	23
	0...1 V	24
	1...5 V	25
	0...5 V	26
	0...10 V	27

**C.5c**<sub>w</sub><sup>SV</sup> **C.5c.2**<sub>w</sub><sup>SV</sup>**°C, °F, K selection and cool joint compensation for X1 & X2 inputs** **E** **J**

Internal compensation	°C	0
	°F	1
	K	2
External compensation	°C	3
	°F	4
	K	5

This code does not appear with Pt100 Ω or linear inputs. When the external cool joint compensation is configured, its value must be set by the parameter **CCJ1, CCJ2** (Tab. F-L)

**C.dd**<sub>w</sub><sup>SV</sup> **C.dd.2**<sub>w</sub><sup>SV</sup>**X1 & X2 decimal point for linear scales** **G** **M**

None	0
1 decimal point	1
2 decimal points	2
3 decimal points	3

This code does not appear when the D table (**C.1n.1**) is selected between 0 and 11.

## Logic input notes

Each one of the the three logic inputs can be freely configured to perform one of the functions listed in table P-Q-R.

Logic signals shall be of the maintained type.

The function is operating when the logic input is "ON". When the logic input is "OFF" the function is inhibited.

### "ON" logic inputs have the priority on the keyboard and Serial comm.s controls.

1 e 1 1 with OFF input returns on automatic

2, 3, 4 with OFF input returns on local set point

If more than one logic input are simultaneously ON to request one of the three memorized set point, the last requested memorized set point will be operating.

5 with OFF input returns on local set point

6 with OFF input returns on remote set point

7 with OFF input keyboard is unlocked

When the keyboard is locked, the other logic inputs and the serial comm.s are operative.

2, 3, 4, 5, 6 & 9 codes depend on the type of Set point previously entered. (Tab. C)

**[E. 1.1] <sup>SV</sup> [E. 1.2] <sup>SV</sup>**

### External cold joint temp. for X1 & X2 inputs

Admitted range	0 ... 50°C
	32 ... 122°F
	273 ... 323 K

Enter a value coherent with the admitted range.

Higher and lower values will not be accepted.

This code is not available with internal

**[E. 1.0] <sup>SV</sup> [E. 1.02] <sup>SV</sup>**

### Beginning value for linear scales for X1 & X2 inputs

- 999 ... 9999

**[E. 6.1] <sup>SV</sup> [E. 6.2] <sup>SV</sup>**

### Full value for linear scales for X1 & X2 inputs

- 999 ... [E. 1.0] -100 or

[E. 1.0] +100 ... 9999

minimum span 100 counts

**[E. 1.1] <sup>SV</sup> [E. 1.2] <sup>SV</sup> [E. 1.3] <sup>SV</sup>**

### Functions of the 3 logic inputs

Functions	P-Q
None	0
Manual control (loop A)	1
1 <sup>st</sup> memorized Set point	2
2 <sup>nd</sup> memorized Set point	3
3 <sup>rd</sup> memorized Set point	4
Remote Set point	5
Local Set point	6
Locked keyboard	7
2 <sup>nd</sup> P.I.D. algorithth	8
Y1 Remote Set point input	9
Y1 Forcing value	10
Manual control (loop B)	11

(see note on the left)

**[E. 1.0] <sup>SV</sup>**

### Remote Set point scale range

		S
Current	4 ... 20 mA	0
	0 ... 20 mA	1
Voltage	1 ... 5 V	2
	0 ... 5 V	3
	0 ... 10 V	4

Is present only if Remote Set point has been selected **Tab. C** codes 2, 3, 4.

**[E. 91] <sup>SV</sup>**

### Control output type

	Y1(▲)	Y1(▼)	T
Single	Relay		0
	Logic		1
	Continuous		2
	Servomotors		3
Double	Relay	Relay	4
	Relay	Logic	5
	Relay	Continuous	6
	Logic	Relay	7
	Logic	Continuous	8
	Continuous	Relay	9
	Continuous	Logic	10
	Continuous	Continuous	11
Servomotors	Logic	12	
Servomotors	Continuous	13	

Codes 8, 10 and 11, can be selected if the 2<sup>nd</sup> analog output option (Y6) is fitted.

These codes depend on the **Table B** (E 4 1).

	If control action is (B Tab.)	Select (M Tab.)
On - Off		0 ... 1
single P.I.D.		2 ... 3
double P.I.D.		4 ... 11

**[E. 91] <sup>SV</sup>**

### Y1 output range

		U
Current	4 ... 20 mA	0
	0 ... 20 mA	1
Voltage	1 ... 5 V	2
	0 ... 5 V	3
	0 ... 10 V	4

The code is available only if the main output (Y1) is of the analog type (see **Table T** codes 2, 5, 9, 11).

**[E. 42] <sup>SV</sup> [E. 43] <sup>SV</sup>**  
**[E. 44] <sup>SV</sup> [E. 45] <sup>SV</sup>**

### Y2-Y3-Y4-Y5 Alarm type

		V-W	X-Y
Disabled			0
X1 Input	N.A.(close)		1
interruption (1)	N.C. (open)		2
Independent	Active high		3
loop A	Active low		4
Deviation	Active high		5
loop A	Active low		6
Band	Active outside		7
loop A	Active inside		8
Output Y1	Active high		9
loop A	Active low		10
X2 Input	N.A.(close)		11
interruption(1)	N.C. (open)		12
Independent	Active high		13
loop B	Active low		14
Deviation	Active high		15
loop B	Active low		16
Band	Active outside		17
loop B	Active inside		18
Output Y1	Active high		19
loop B	Active low		20
Ratio	Active high		21
	Active low		22

(\*) Only for thermolements, 4 ... 20mA and 1 ... 5V

Y4 and/or Y5 outputs are not available if the control output has been all ready used as single or double relay servomotor output. **Tab. T**

Codes 0, 3, 4, 5, 6, 7, 9, 12, 13

**[E. 46] <sup>SV</sup>**  **OPTION**

### Y6 2<sup>nd</sup> analog output type

		Z
Disabled		0
Retransmission	Measure X1	1
	Set point W	2
	Output Y1	3
	Output Y1(channel ▼)	4
	Deviation 0 ... 25%	5
	Measure X2	6

This code are available only if the 2<sup>nd</sup> analog output has not been used as second control output (E. 46 **Tab T** codes 8, 10, 11)

**[E. 46] <sup>SV</sup>**

### Y6 output range

		*
Current	4 ... 20 mA	0
	0 ... 20 mA	1
Voltage	1 ... 5 V	2
	0 ... 5 V	3
	0 ... 10 V	4

The code is not available if E. 46 is disabled, if double output is selected and Y1 (channel ▼) is logic or continuous type.

**Tab. Z** - Codes 1, 2, 3, 4 or

**Tab. T** - Codes 8, 10, 11

When the configuration phase is completed the programming phase shall be started.

## 6.1•

## Main menu

The main menu allows controller configuration and parameterization, Auto tune launch (start), indication of target Set point and serial comm.s address.

Press **F** key during normal operation, main menu functions are shown in the following sequence:

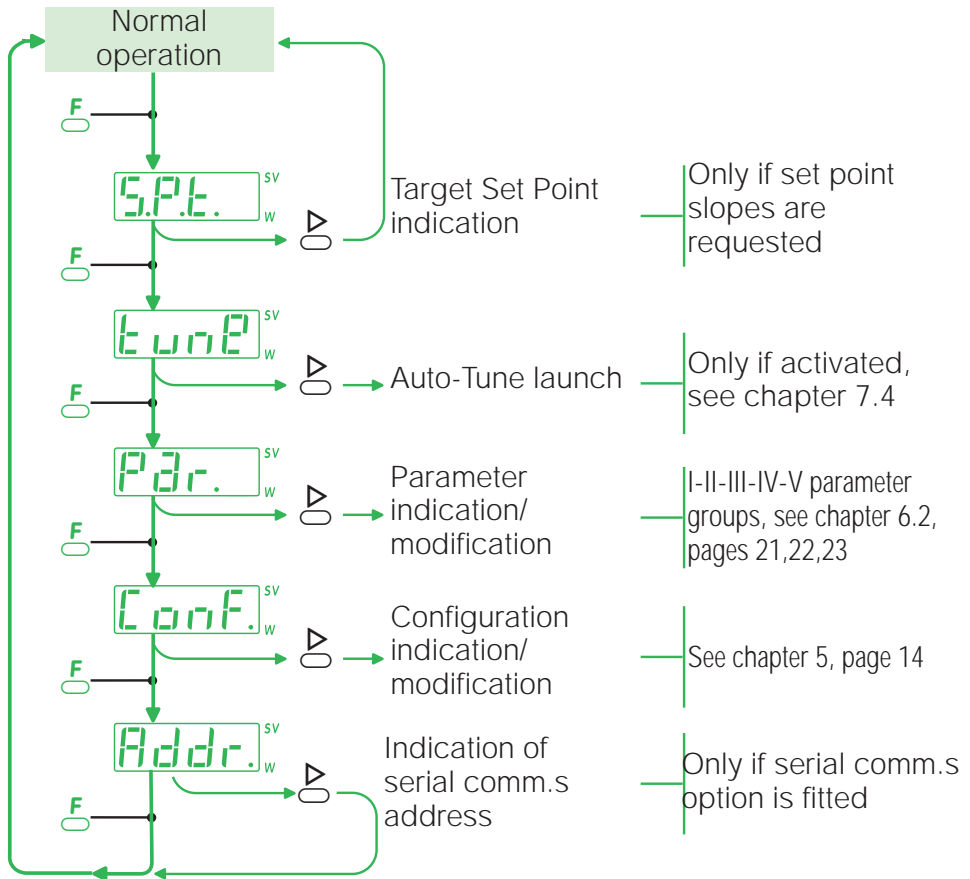

## 6.2•

## Parameters access

Starting from normal operation, press **F** key repeatedly until the display W/SV shows **Par.**<sub>x</sub>, press **▶** key to reach the first parameter of the first group **S.P.**<sub>1</sub>

Parameters are divided into 4 homogeneous groups.

Press **F** key to reach the next parameter group.

The V group of parameters is protected by a Password, enter **1111**<sub>x</sub> when display shows **PASS**<sub>x</sub>.

## 6.3 Parameterization



This procedure is time delayed. If no keys are pressed for about 30 seconds, the instrument returns to the normal operation.

### 1<sup>st</sup> GROUP

Parameter indication/modification

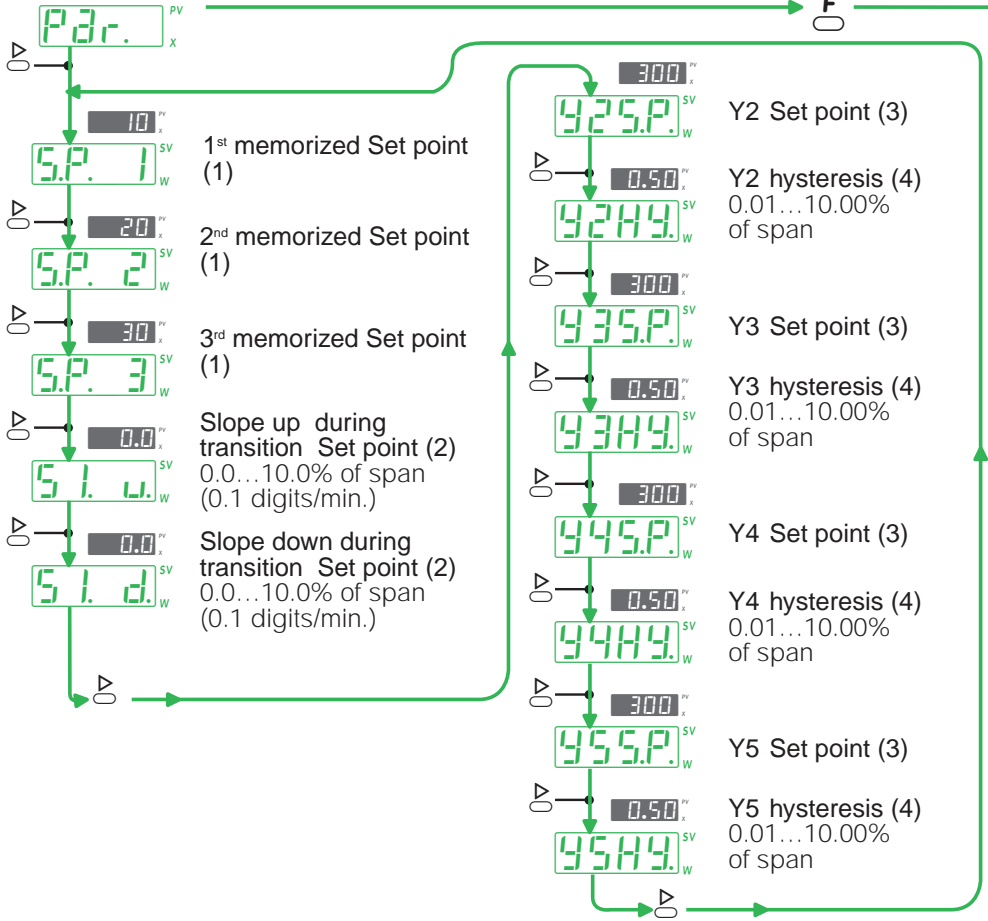

### Block diagram for 1 Std. Loop with single and/or double output

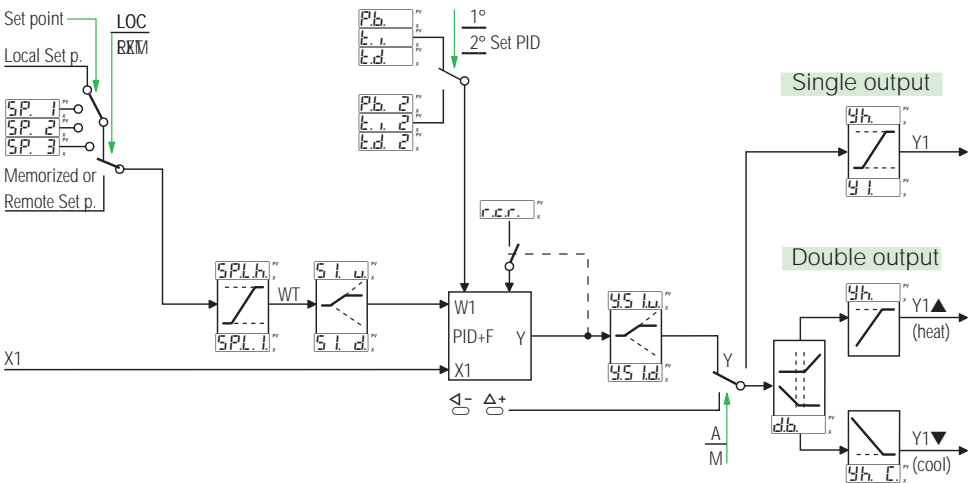

When the QD controller is configured with a double action (e.g. Heat/Cool) two different outputs are used from the same PID algorithm. In addition some specific parameters are available to help the PID algorithm. *r.c.r.* parameter which defines the ratio between Heating Proportional band and Cooling Proportional band. *db* parameter instead set the dead zone transition among the two Heating & Cooling actions. Besides the Maximum Y1 output value can be modified by *Yh.* and *Yh.C.* for the different outputs.

2<sup>nd</sup> GROUP

For a quick and easy use, parameters of the 2<sup>nd</sup> group are shown, herebelow, in accordance with the selected "Algoorythm and control action"

Single and double P.I.D. algoorythm and Control action (B table 2 - 3 - 4 - 5)

P.I.D. algoorythm and Control action with only servomotors output (B table 2 - 3 and T table 3)

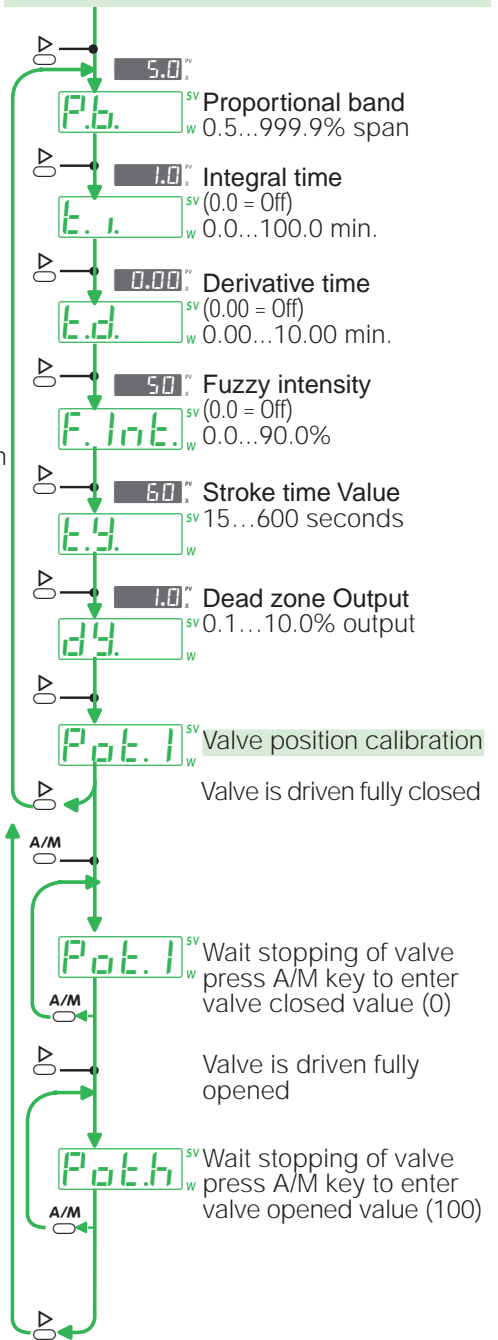
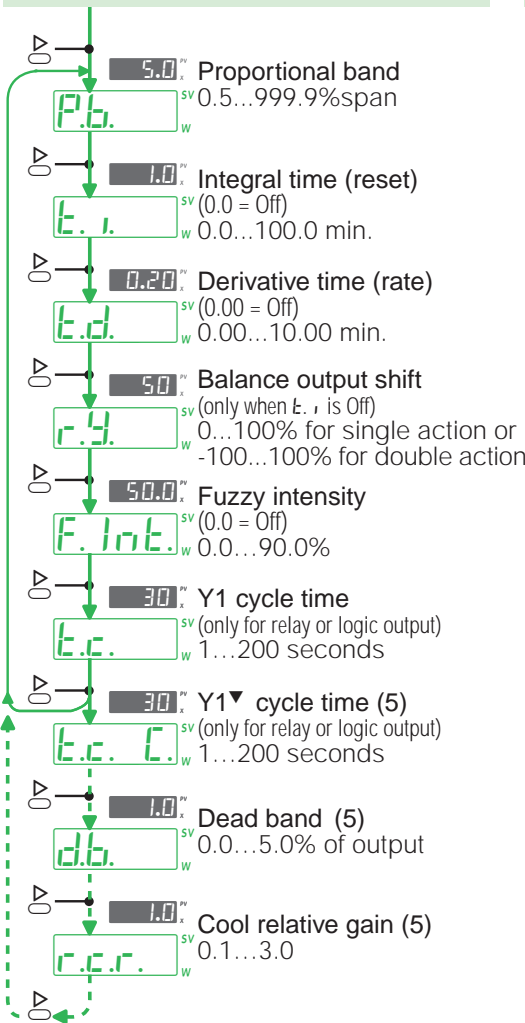

On-Off algoorythm and control action (B table 0 - 1)

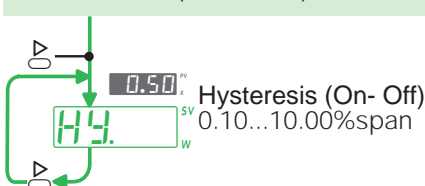

3<sup>rd</sup> GROUP

4<sup>th</sup> GROUP

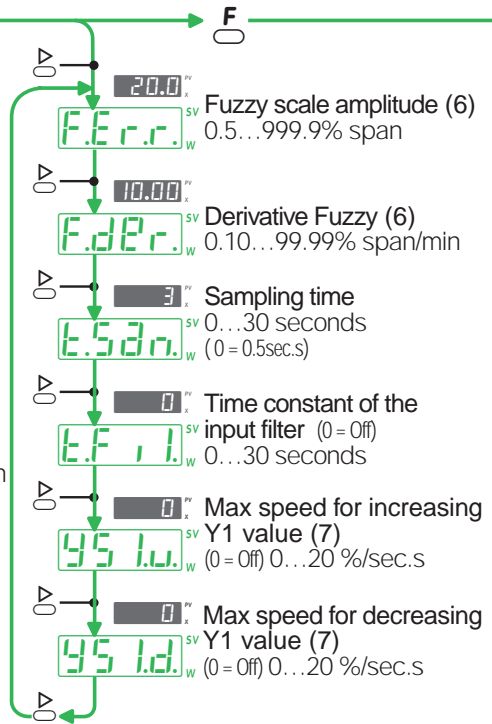
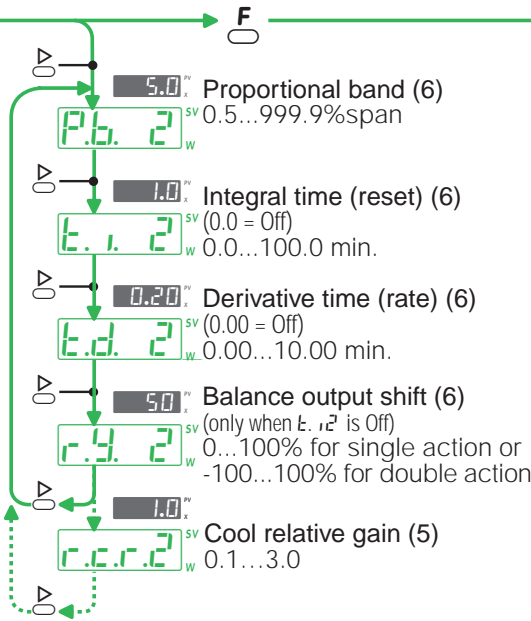

Notes

- 1 The 3 memorized Set points are displayed only if the "Set point type" code is selected as "local and 3 memorized" (E. 5P, Table C, see page 16). The memorized Set points are adjustable over the full scale range but within the Set point limits entered under the IV parameters group.
- 2 If set to 0.0, the slope is excluded. The Set point change is of the step type. The maximum set value is 10% of span expressed in digits/min. Example:  
 Range: -200...600°C  
 Span: 800°C  
 Maximum set value: 80.0 digit/min  
 Corresponding to: 80.0°C/min
- 3 This parameter is not displayed if the "alarm type" code is selected as "Disabled" or "Input interruption" (V-W-X-Y Tables 0, 1, 2, see page 19). The set range of Y2 and Y3 Set point, changes in accordance with the configuration of the "alarm type" as follows:
  - Independent: over the full scale range
  - Deviation: -300...+300
  - Band: 0...300
- 4 This parameter is not displayed if the "alarm type" code is selected as "Disabled" or "Input interruption" (V-W-X-Y Tables 0, 1, 2, see page 19).
- 5 Only for double action output.
- 6 Not displayed if the "Algorithm and control action" is "On-Off" or if one of the 3 logic inputs is configured as "2<sup>nd</sup> PID algorithm" (P\_Q\_R table code 0)
- 7 Not displayed if the "Algorithm and control action" is "On-Off" or if the "Control Action" is selected for servomotors.
- 8 Functions and parameters protection level code.
- 9 Parameter is present if one of the 3 logic inputs is configured as "Y1 forcing value" (P-Q-R Table code 10)

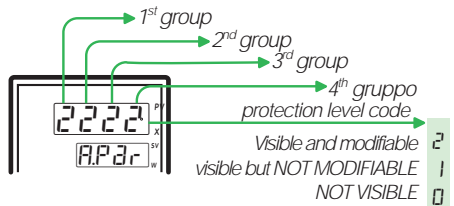



## 5th GROUP

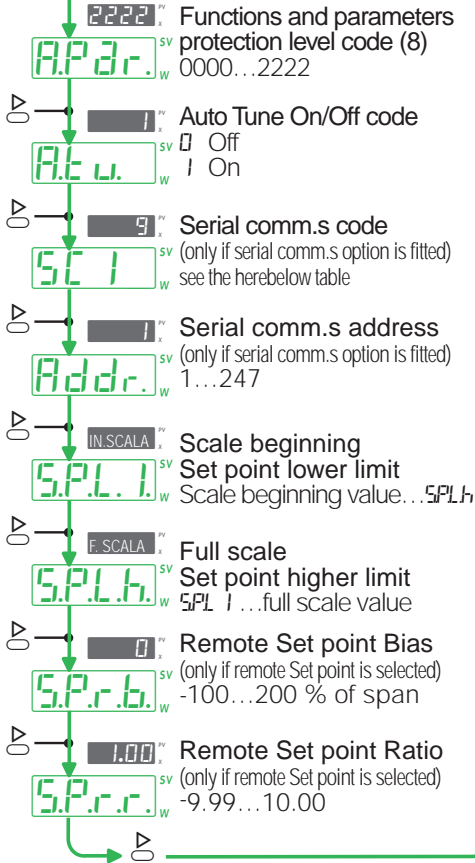
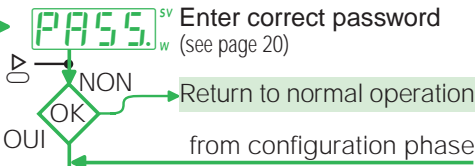

Code	Protocol	Baud R.	Operating M.
0	—	—	Disabled
1	ModBus	9600	
2	ModBus	4800	
3	ModBus	2400	
4	ModBus	1200	
5	JBus	9600	Read only
6	JBus	4800	
7	JBus	2400	
8	JBus	1200	
9	ModBus	9600	
10	ModBus	4800	
11	ModBus	2400	
12	ModBus	1200	Read and write
13	JBus	9600	
14	JBus	4800	
15	JBus	2400	
16	JBus	1200	
17	ModBus	9600	
18	ModBus	4800	
19	ModBus	2400	Supervision system or local mode
20	ModBus	1200	
21	JBus	9600	
22	JBus	4800	
23	JBus	2400	
24	JBus	1200	

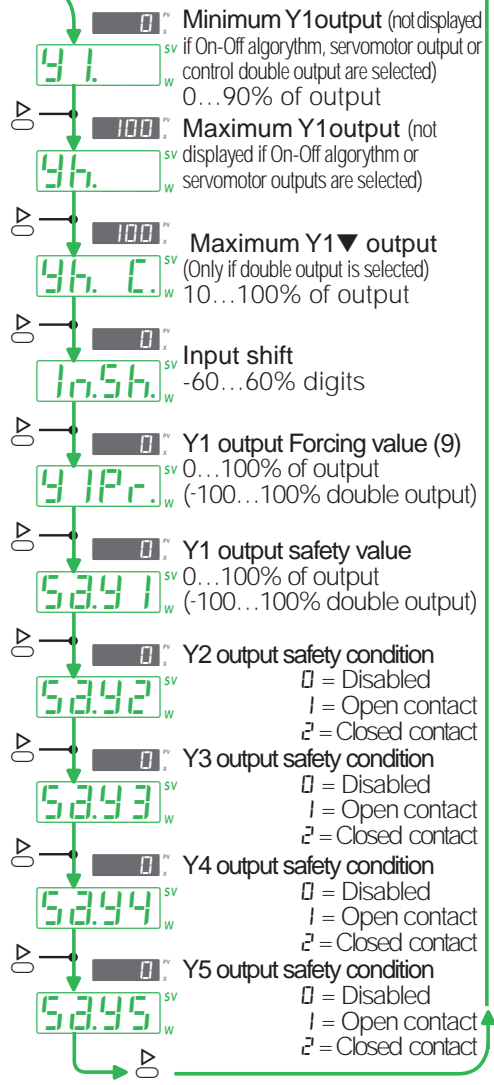

## 6.3 Parameterization



This procedure is time delayed. If no keys are pressed for about 30 seconds, the instrument returns to the normal operation.

### 1<sup>st</sup> GROUP

Parameter indication/modification

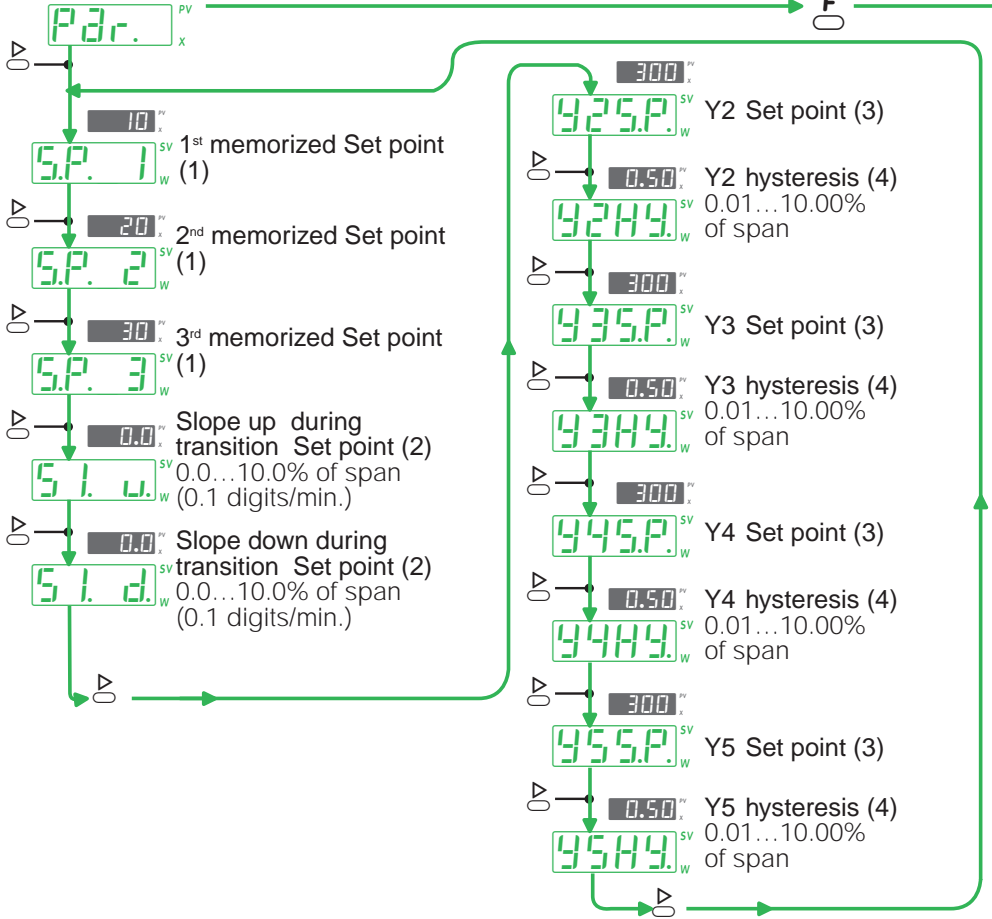

### Block diagram for 1 Cascade Loop

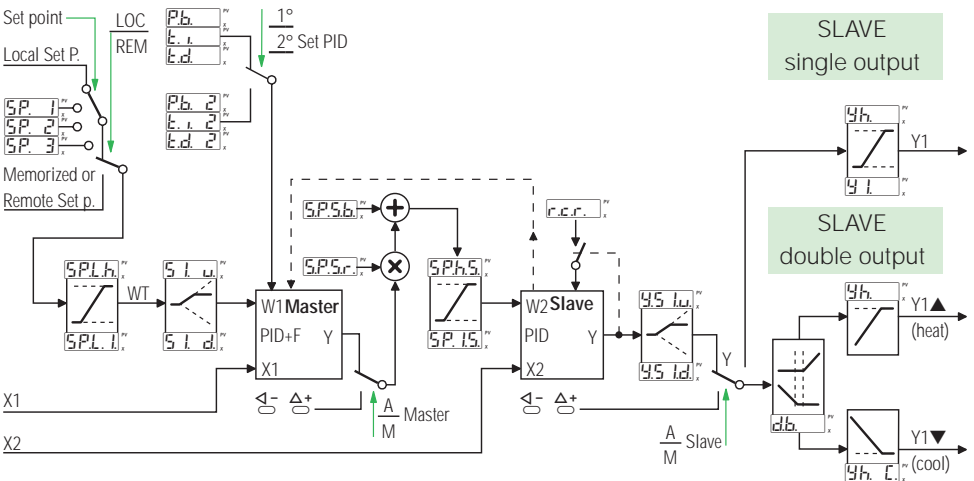

When the QD controller is configured as "1 Cascade Loop" the control output (Y1) of Master controller is manipulated by the following mathematic expression:  
 $W2 = Y \cdot S.P.5.r + S.P.5.b$ . This Set point can be limited by the  $S.P.15$  and  $S.P.5$  parameters. A Blik signal inhibits the action of the Master controller. When the Slave output is saturated or the Slave controller is operating in Manual mode. Usually the Slave Set Point is not modifiable by keys because it depends on the above formula only. Anyhow it can be set only when the Master Loop is operating in Manual mode.

2<sup>nd</sup> GROUP

For a quick and easy use, parameters of the 2<sup>nd</sup> group are shown, herebelow, in accordance with the selected "Algorithm and control action"

Single and double P.I.D. algorithm and Control action (B table 5 - 7-B-9 - 10 - 11 - 12 - 13)

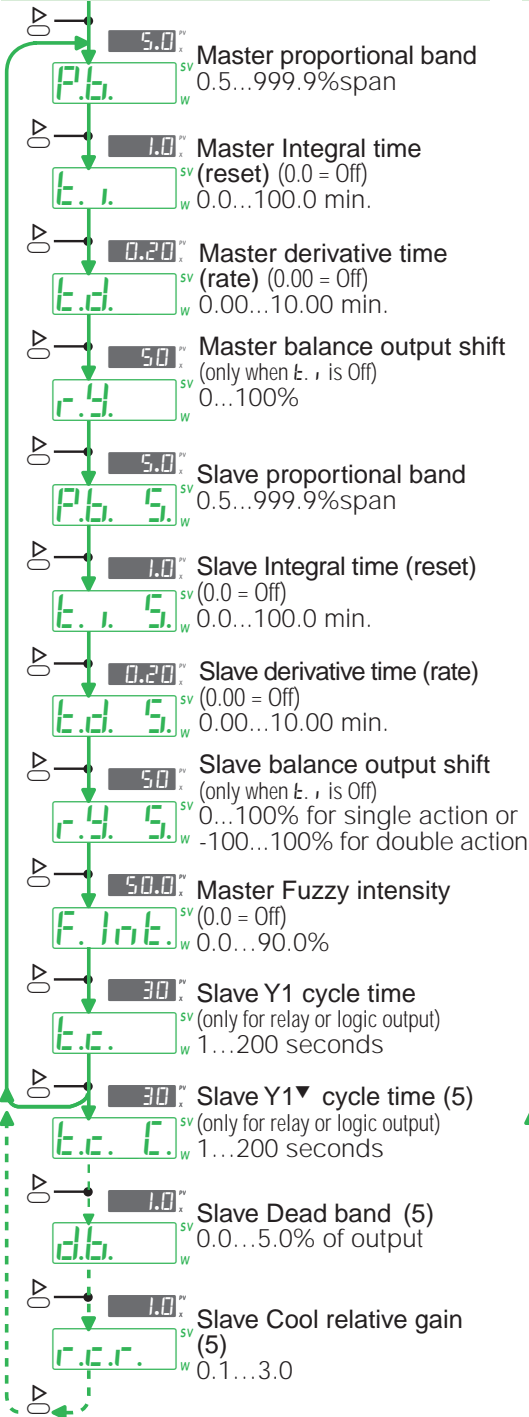

P.I.D. algorithm and Control action with only servomotors output (B table 5 - 7-B-9 & T=3)

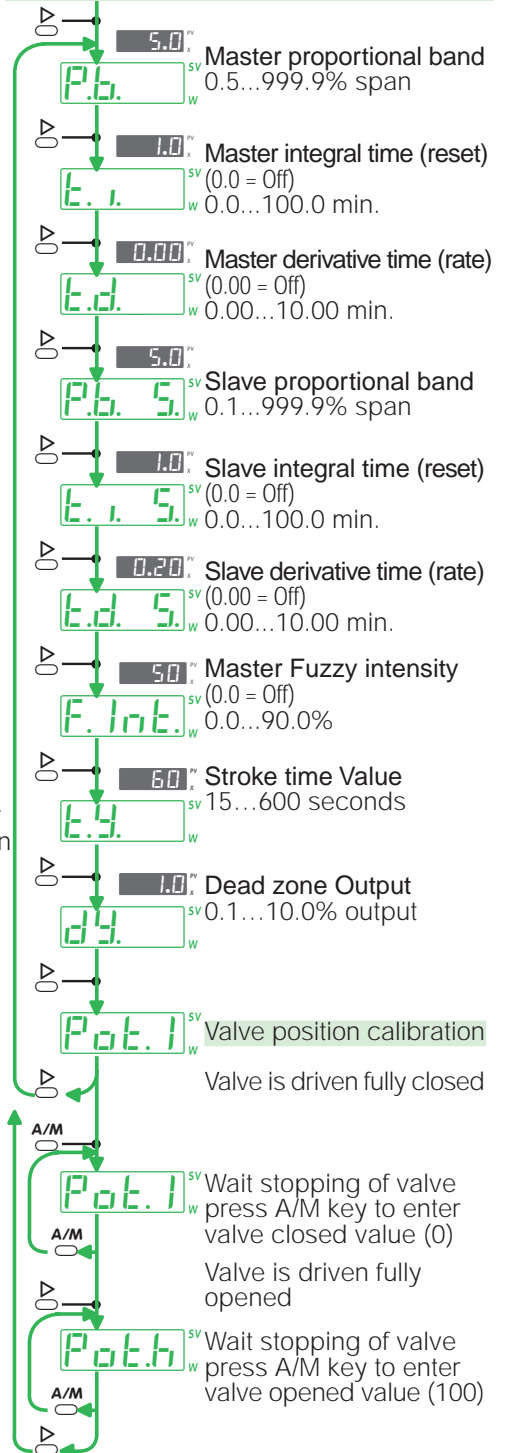

3<sup>rd</sup> GROUP

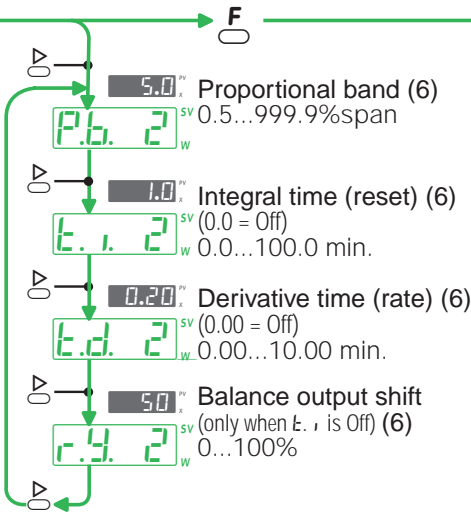

4<sup>th</sup> GROUP

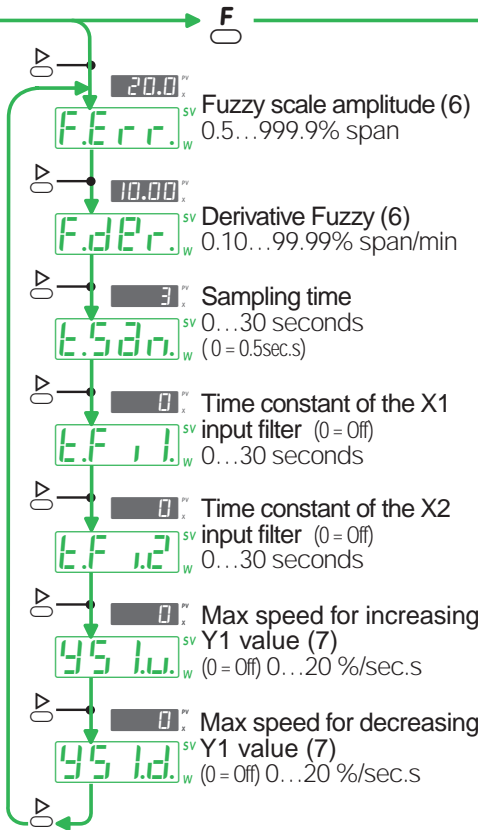

Notes

- The 3 memorized Set points are displayed only if the "Set point type" code is selected as "local and 3 memorized" (E. 5P); Table C, see page 18). The memorized Set points are adjustable over the full scale range but within the Set point limits entered under the V parameters group.
- If set to 0.0, the slope is excluded. The Set point change is of the step type. The maximum set value is 10% of span expressed in digits/min. Example:  
 Range: -200...600°C  
 Span: 800°C  
 Maximum set value: 80.0 digit/min  
 Corresponding to: 80.0°C/min
- This parameter is not displayed if the "alarm type" code is selected as "Disabled" or "Input interruption" (V-W-X-Y Tables 0, 1, 2, see page 19). The set range of Y2 and Y3 Set point, changes in accordance with the configuration of the "alarm type" as follows:
  - Independent: over the full scale range
  - Deviation: -300...+300
  - Band: 0...300

- This parameter is not displayed if the "alarm type" code is selected as "Disabled" or "Input interruption" (V-W-X-Y Tables 0, 1, 2, see page 19).
- Only for double action output.
- Not displayed if the "Algorithm and control action" is "On-Off" or if one of the 3 logic inputs is configured as "2<sup>nd</sup> PID algorithm" (P-Q-R table code B)
- Not displayed if the "Algorithm and control action" is "On-Off" or if one of the "Control Action" is selected for servomotors.
- Functions and parameters protection level code.

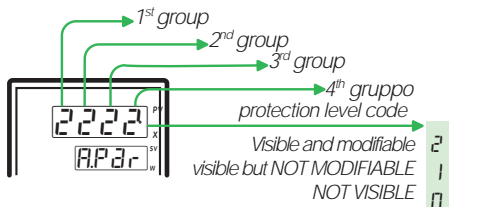

- Parameter is present if one of the 3 logic inputs is configured as "Y1 forcing value" (P-Q-R Table code 10)

## 5<sup>th</sup> GROUP

**PASS.** <sup>sv</sup> Enter correct password  
(see page 20)

NO → Return to normal operation  
SI → from configuration phase

**2222** <sup>rv</sup> Functions and parameters  
protection level code (8)  
0000...2222

**APAr.** <sup>sv</sup> Auto Tune On/Off code  
0 Off  
1 On

**Actu.** <sup>sv</sup> Serial comm.s code  
(only if serial comm.s option is fitted)  
see the herebelow table

**9** <sup>sv</sup> Serial comm.s address  
(only if serial comm.s option is fitted)  
1...247

**SC1** <sup>sv</sup> Master scale beginning  
Set point lower limit  
X1 Scale beginning value...5PL<sub>h</sub>

**1** <sup>sv</sup> Master full scale  
Set point higher limit  
5PL<sub>l</sub>...X2 full scale value

**0** <sup>sv</sup> Remote Set point Bias  
(only if remote Set point is selected)  
-100...200 % of span

**1.00** <sup>sv</sup> Remote Set point Ratio  
(only if remote Set point is selected)  
-9.99...10.00

**0** <sup>rv</sup> Slave Set point Bias  
-100...200 % of span

**5.P.5.6** <sup>sv</sup> Slave Set point Ratio  
-9.99...10.00

**1.00** <sup>rv</sup> Scale beginning  
Set point lower limit  
Scale beginning value...5PL<sub>h</sub>

**IN.SCALA** <sup>rv</sup> Full scale  
Set point higher limit  
5PL<sub>l</sub>...full scale value

**0** <sup>rv</sup> Minimum Y1 output (not displayed  
if On-Off algorithm, servomotor output or  
double output are selected)  
0...90% of output

**91** <sup>sv</sup> Maximum Y1 output (not  
displayed if On-Off algorithm or  
servomotor output are selected)  
0...100%

**100** <sup>sv</sup> Maximum Y1▼ output  
(Only if double output is selected)  
10...100% of output

**100** <sup>sv</sup> X1 Input shift  
-60...60% digits

**0** <sup>sv</sup> X2 Input shift  
-60...60% digits

**0** <sup>sv</sup> Y1 output forcing value (9)  
0...100% of output  
(-100...100% double output)

**91Pr.** <sup>sv</sup> Y1 output safety value  
0...100% of output  
(-100...100% double output)

**0** <sup>sv</sup> Y2 output safety condition  
0 = Disabled  
1 = Open contact  
2 = Closed contact

**52.91** <sup>sv</sup> Y3 output safety condition  
0 = Disabled  
1 = Open contact  
2 = Closed contact

**52.92** <sup>sv</sup> Y4 output safety condition  
0 = Disabled  
1 = Open contact  
2 = Closed contact

**52.93** <sup>sv</sup> Y5 output safety condition  
0 = Disabled  
1 = Open contact  
2 = Closed contact

**52.94** <sup>sv</sup> Y2 output safety condition  
0 = Disabled  
1 = Open contact  
2 = Closed contact

**52.95** <sup>sv</sup> Y3 output safety condition  
0 = Disabled  
1 = Open contact  
2 = Closed contact

**52.96** <sup>sv</sup> Y4 output safety condition  
0 = Disabled  
1 = Open contact  
2 = Closed contact

**52.97** <sup>sv</sup> Y5 output safety condition  
0 = Disabled  
1 = Open contact  
2 = Closed contact

Code	Protocol	Baud R.	Operating M.
0	—	—	Disabled
1	ModBus	9600	
2	ModBus	4800	
3	ModBus	2400	
4	ModBus	1200	Read only
5	JBus	9600	
6	JBus	4800	
7	JBus	2400	
8	JBus	1200	
9	ModBus	9600	
10	ModBus	4800	
11	ModBus	2400	Read and write
12	ModBus	1200	
13	JBus	9600	
14	JBus	4800	
15	JBus	2400	
16	JBus	1200	
17	ModBus	9600	
18	ModBus	4800	
19	ModBus	2400	Supervision system or local mode
20	ModBus	1200	
21	JBus	9600	
22	JBus	4800	
23	JBus	2400	
24	JBus	1200	

## 6.3 Parameterization



This procedure is time delayed. If no keys are pressed for about 30 seconds, the instrument returns to the normal operation.

### 1<sup>st</sup> GROUP

Parameter indication/modification

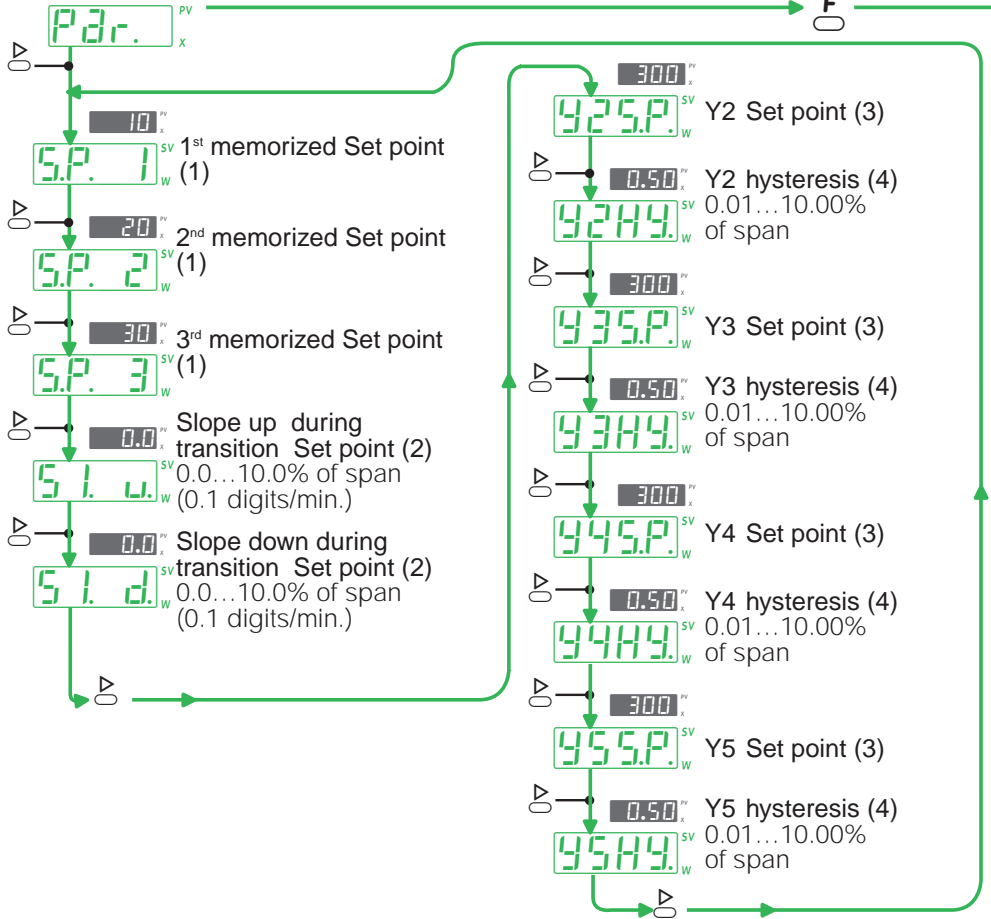

### Block diagram for 1 Ratio Loop

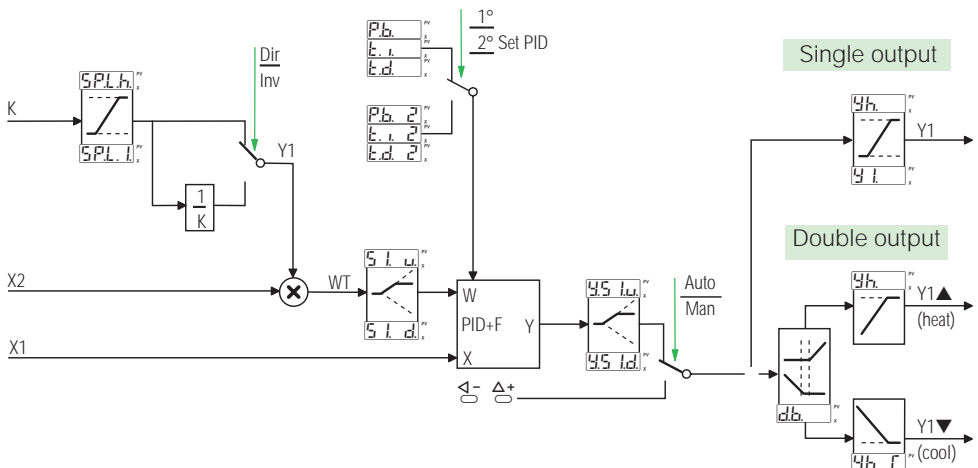

When the QD controller is configured as "1 Ratio Loop" the Target Set point (WT), applied to the PID algorithm, is the result of a multiplication (or division if a Reverse Ratio is configured), between the variable (X2) and a constant factor (K) (request ratio).

Example: Direct Ratio  $WT = X2 \cdot K$

$$\text{Reverse Ratio } WT = X2 \cdot \frac{1}{K}$$

2<sup>nd</sup> GROUP

For a quick and easy use, parameters of the 2<sup>nd</sup> group are shown, herebelow, in accordance with the selected "Algoorythm and control action"

P.I.D. algoorythm and Control action (B table 14 - 15 - 16 - 17)

P.I.D. algoorythm and Control action with only servomotors output (B table 14 - 15 - 16 - 17 and T table 3)

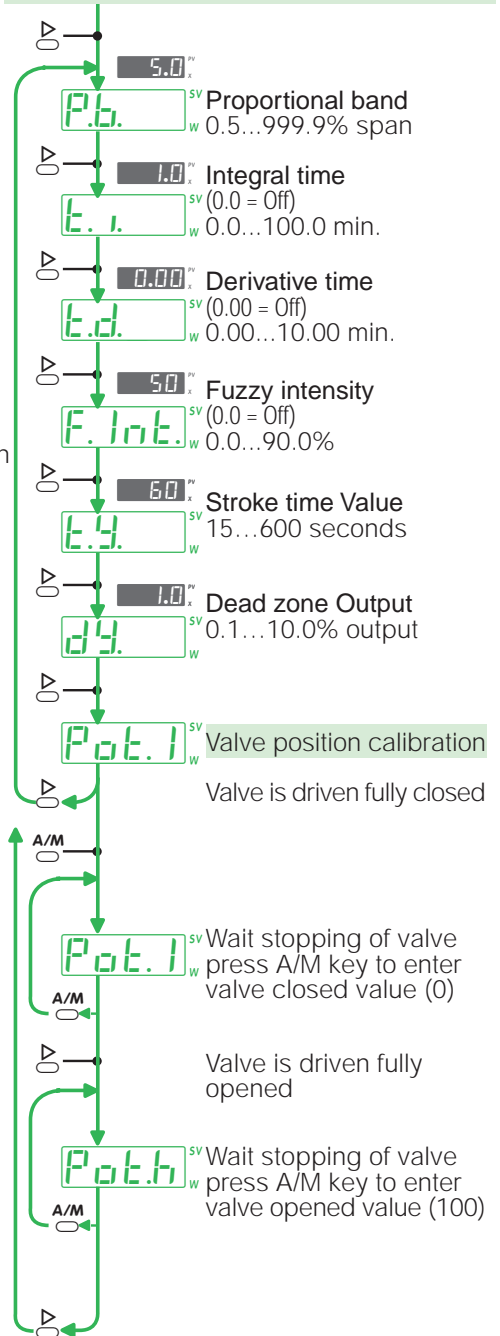
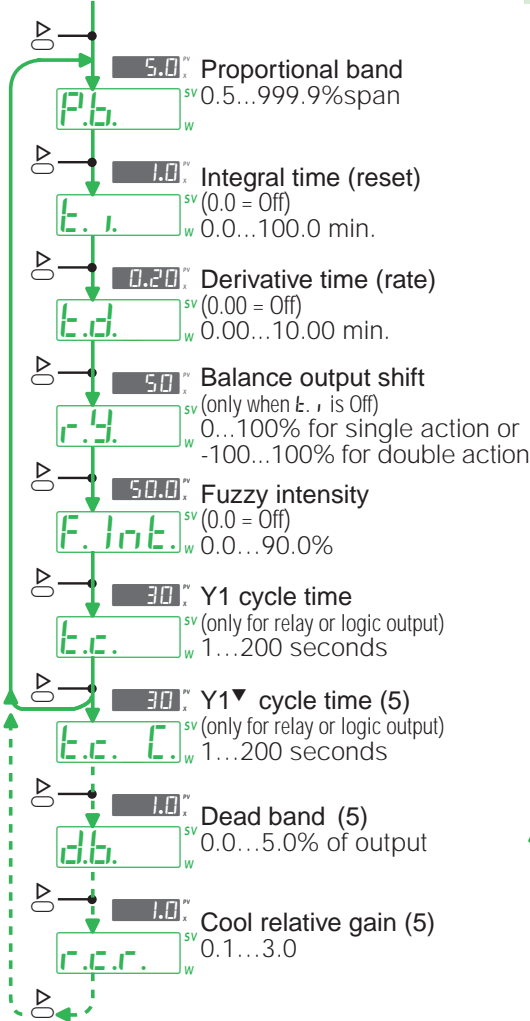

3<sup>rd</sup> GROUP

4<sup>th</sup> GROUP

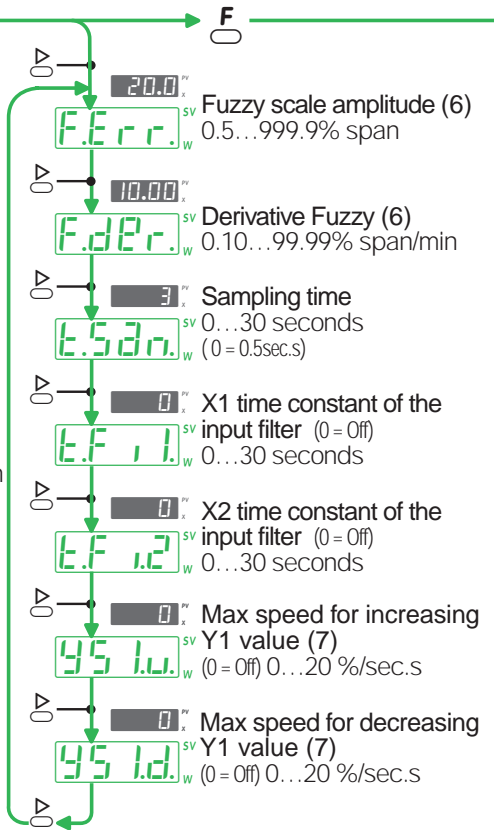
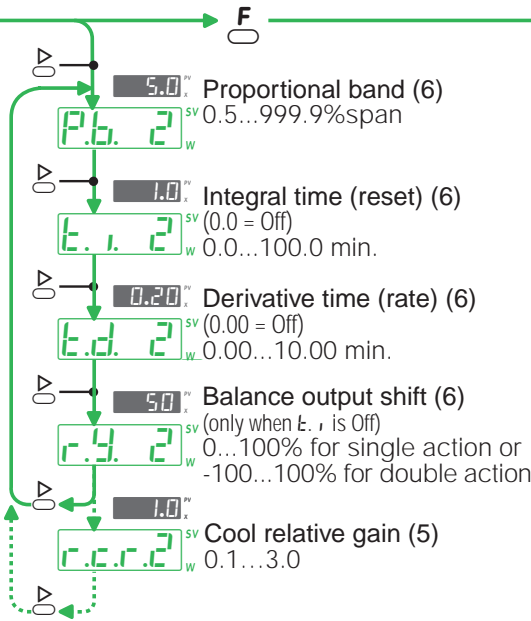

Notes

- The 3 memorized Set points are displayed only if the "Set point type" code is selected as "local and 3 memorized" (E. 5P), Table C, see page 18). The memorized Set points are adjustable over the full scale range but within the Set point limits entered under the IV parameters group.
- If set to 0.0, the slope is excluded. The Set point change is of the step type. The maximum set value is 10% of span expressed in digits/min. Example:  
Range: -200...600°C  
Span: 800°C  
Maximum set value: 80.0 digit/min  
Corresponding to: 80.0°C/min
- This parameter is not displayed if the "alarm type" code is selected as "Disabled" or "Input interruption" (V-W-X-Y Tables 0, 1, 2, see page 19)  
The set range of Y2 and Y3 Set point, changes in accordance with the configuration of the "alarm type" as follows:
  - Independent: over the full scale range
  - Deviation: -300...+300
  - Band: 0...300

- This parameter is not displayed if the "alarm type" code is selected as "Disabled" or "Input interruption" (V-W-X-Y Tables 0, 1, 2, see page 19)
- Only for double action output.
- Not displayed if the "Algorithm and control action" is "On-Off" or if one of the 3 logic inputs is configured as "2<sup>nd</sup> PID algorithm" (P-Q-R table code B)
- Not displayed if the "Algorithm and control action" is "On-Off" or if the "Control Action" is selected for servomotors.
- Functions and parameters protection level code.

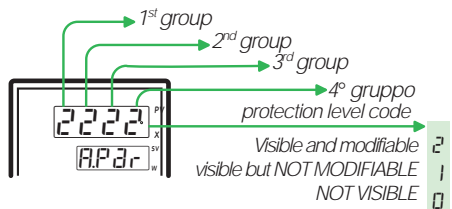

- Parameter is present if one of the 3 logic inputs is configured as "Y1 forcing value" (P-Q-R Table code 10)



## 5<sup>th</sup> GROUP

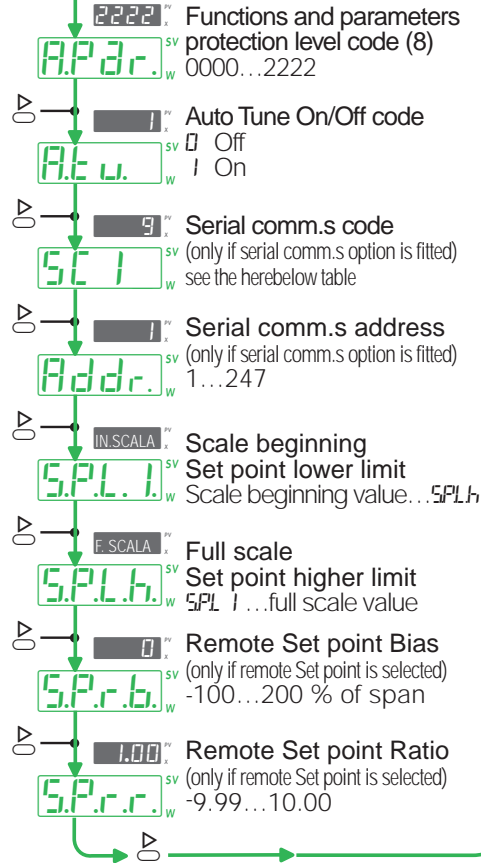
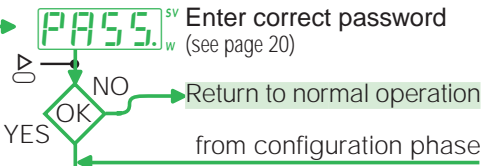

Code	Protocol	Baud R.	Operating M.
0	—	—	Disabled
1	ModBus	9600	
2	ModBus	4800	
3	ModBus	2400	
4	ModBus	1200	
5	JBus	9600	Read only
6	JBus	4800	
7	JBus	2400	
8	JBus	1200	
9	ModBus	9600	
10	ModBus	4800	
11	ModBus	2400	
12	ModBus	1200	Read and write
13	JBus	9600	
14	JBus	4800	
15	JBus	2400	
16	JBus	1200	
17	ModBus	9600	
18	ModBus	4800	
19	ModBus	2400	Supervision system or local mode
20	ModBus	1200	
21	JBus	9600	
22	JBus	4800	
23	JBus	2400	
24	JBus	1200	

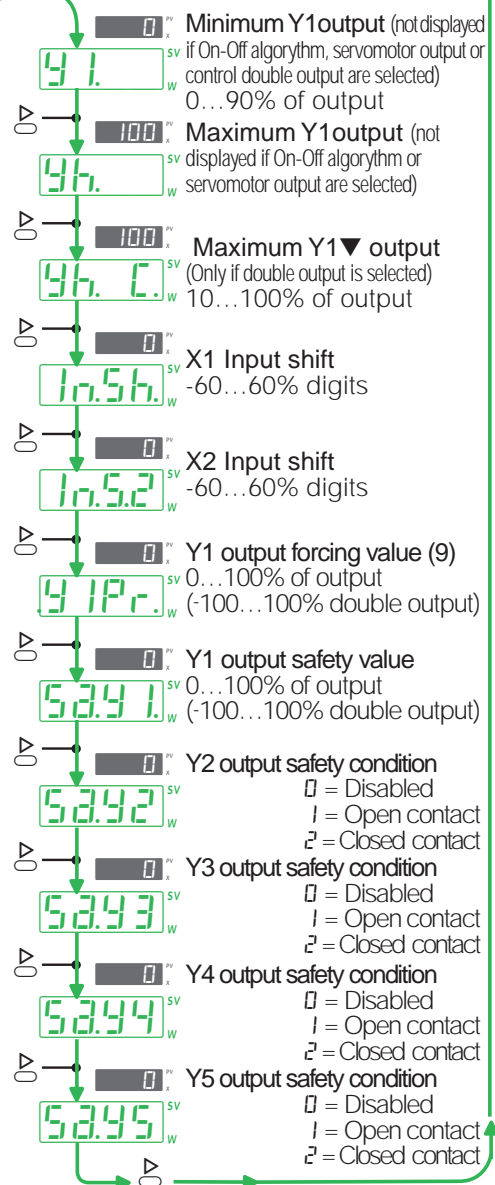

## 6.3 Parameterization



This procedure is delayed. If no keys are pressed for about 30 seconds, the instrument returns to the normal operation.

### 1<sup>st</sup> GROUP

Parameter indication/modification

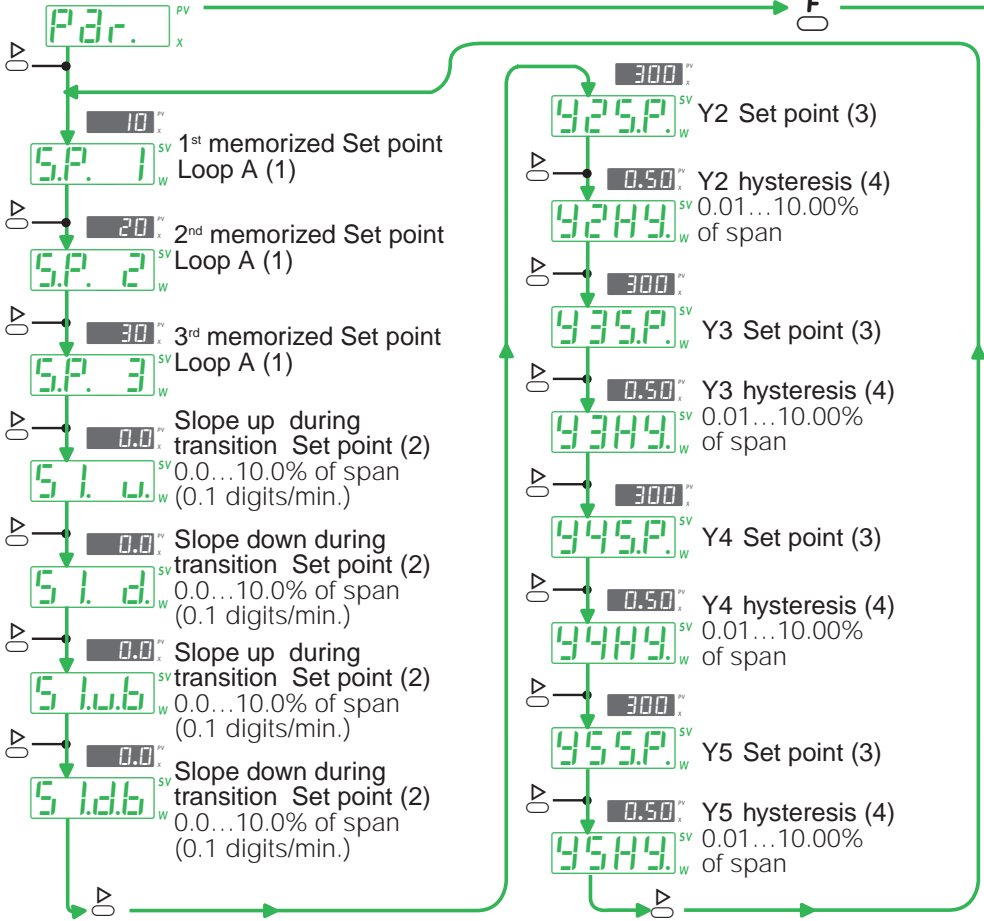

### Block diagram for 2 independent loops

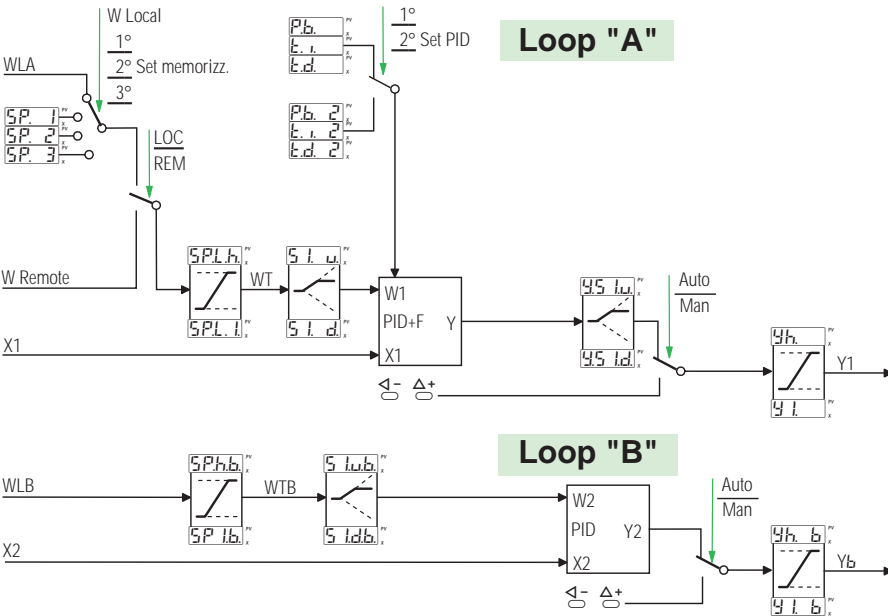

When the QD controller is configured as "2 independent Loops", the following functions belong to the first loop (Loop A) only: Fuzzy logic, memorized Set point 2nd set of PID algorithm (from logic inputs or serial comm.s). The second loop (Loop B) can be used as simple PID loop only.

2<sup>nd</sup> GROUP

For a quick and easy use, parameters of the 2<sup>nd</sup> group are shown, herebelow, in accordance with the selected "Algorithm and control action"

P.I.D. algorithm and Control action with only servomotors output  
(B table 1B - 19 - 20 - 21 and T table 12 - 13)

Single and double P.I.D. algorithm and Control action (B table 1B - 19 - 20 - 21)

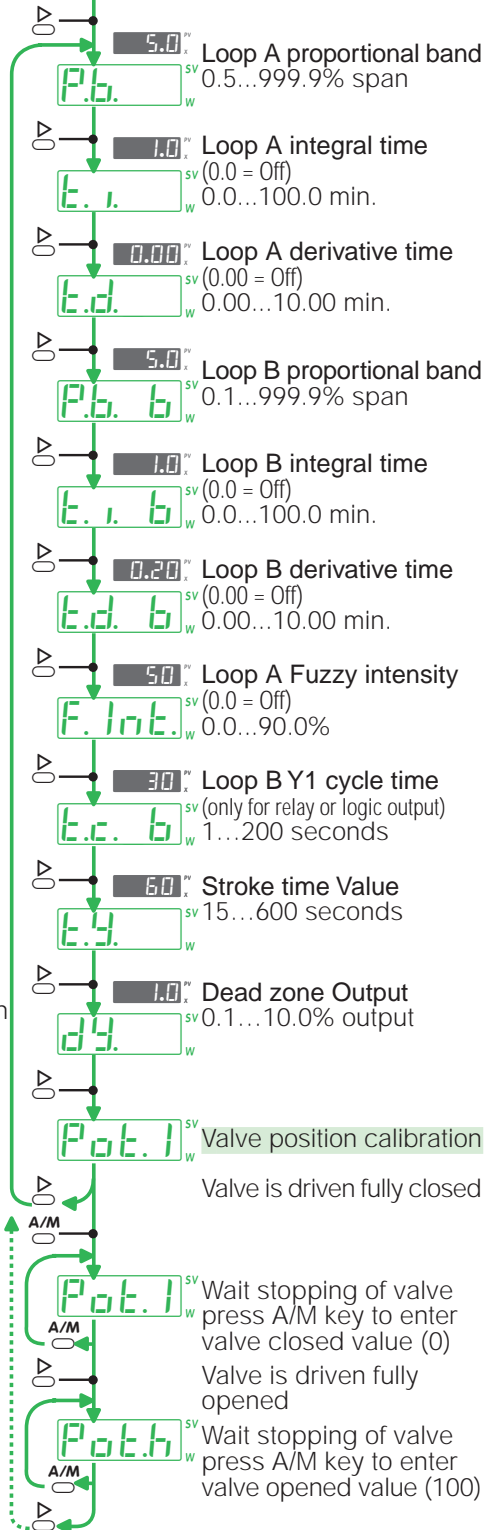
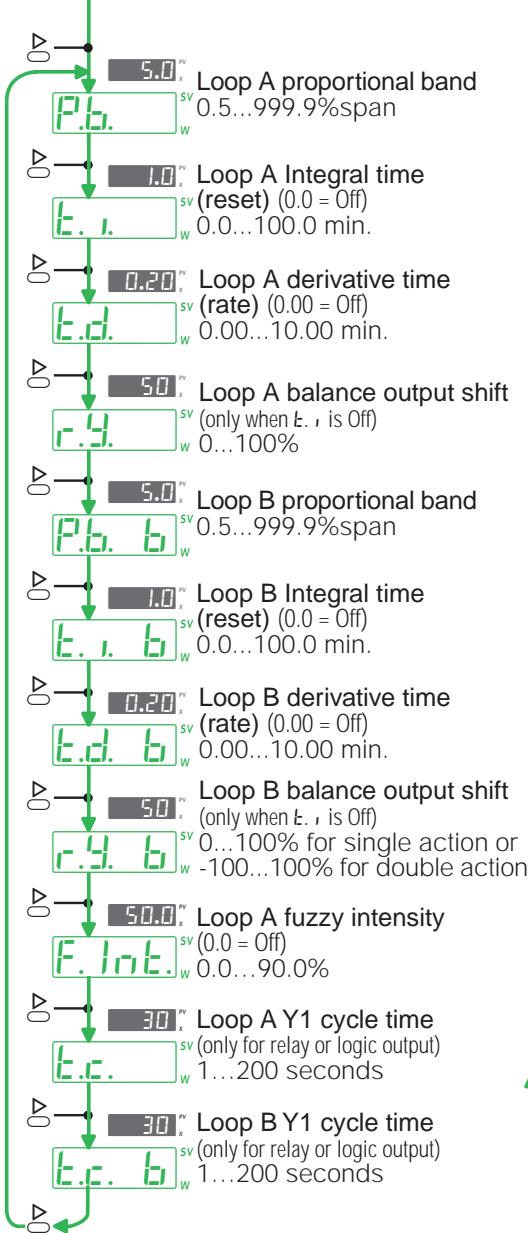

3<sup>rd</sup> GROUP

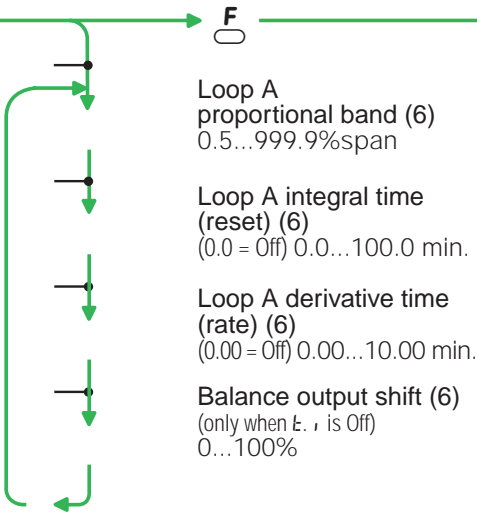

4<sup>th</sup> GROUP

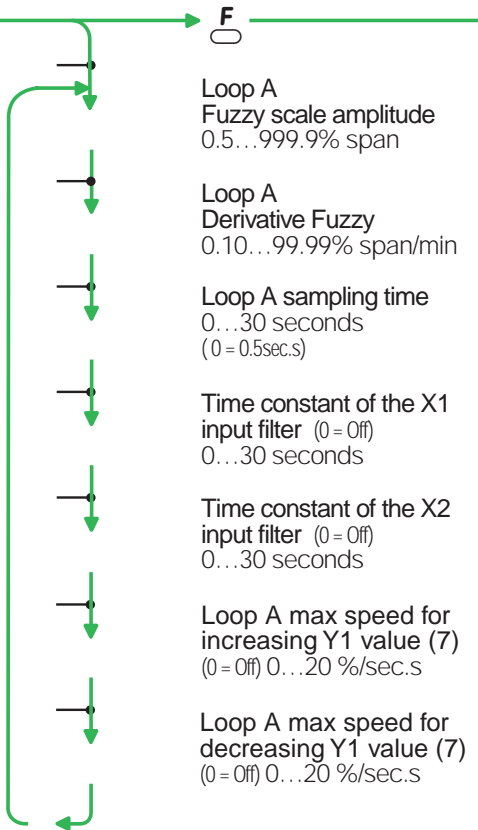

E

Notes

- 1 The 3 memorized Set points are displayed only if the "Set point type" code is selected as "local and 3 memorized" (E. 5P), Table C, see page 18). The memorized Set points are adjustable over the full scale range but within the Set point limits entered under the V parameters group.
- 2 If set to 0.0, the slope is excluded. The Set point change is of the step type. The maximum set value is 10% of span expressed in digits/min. Example:  
Range: -200...600°C  
Span: 800°C  
Maximum set value: 80.0 digit/min  
Corresponding to: 80.0°C/min
- 3 This parameter is not displayed if the "alarm type" code is selected as "Disabled" or "Input interruption" (V-W-X-Y Tables 1, 2, see page 19)  
The set range of Y2 and Y3 Set point, changes in accordance with the configuration of the "alarm type" as follows:
  - Independent: over the full scale range
  - Deviation: -300...+300
  - Band: 0...300

- 4 This parameter is not displayed if the "alarm type" code is selected as "Disabled" or "Input interruption" (V-W-X-Y Tables 1, 2, see page 19)
- 6 Not displayed if one of the 3 logic inputs is configured as "2<sup>nd</sup> PID algorithm" (P-Q-R table code 8)
- 7 Not displayed if the "Control Action" is selected for servomotors.
- 8 Functions and parameters protection level code.

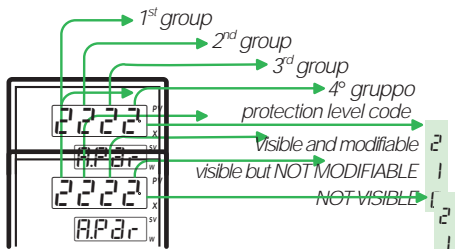

- 9 Parameter is present if one of the 3 logic inputs is configured as "Y1 forcing value" (P-Q-R Table code 10)

## 5<sup>th</sup> GROUP

**PASS.** <sup>SV</sup> Enter correct password  
<sub>W</sub> (see page 20)

NO → Return to normal operation  
 YES → from configuration phase

**2222** <sup>SV</sup> Functions and parameters  
<sub>W</sub> protection level code (8)  
 0000...2222

**1** <sup>SV</sup> Auto Tune On/Off code  
<sub>W</sub>  Off  
 On

**9** <sup>SV</sup> Serial comm.s code  
<sub>W</sub> (only if serial comm.s option is fitted)  
 see the herebelow table

**1** <sup>SV</sup> Serial comm.s address  
<sub>W</sub> (only if serial comm.s option is fitted)  
 1...247

**IN.SCALA** <sup>SV</sup> Loop A scale beginning  
<sub>W</sub> Set point lower limit  
 Scale beginning value... **5PL<sub>l</sub>**

**F.SCALA** <sup>SV</sup> Loop A full scale  
<sub>W</sub> Set point higher limit  
 5PL<sub>l</sub> ... full scale value

**IN.SCALA** <sup>SV</sup> Loop B scale beginning  
<sub>W</sub> Set point lower limit  
 Scale beginning value... **5PL<sub>lb</sub>**

**F.SCALA** <sup>SV</sup> Loop B full scale  
<sub>W</sub> Set point higher limit  
 5PL<sub>lb</sub> ... full scale value

Code	Protocol	Baud R.	Operating M.
0	—	—	Disabled
1	ModBus	9600	Read only
2	ModBus	4800	
3	ModBus	2400	
4	ModBus	1200	
5	JBus	9600	Read and write
6	JBus	4800	
7	JBus	2400	
8	JBus	1200	
9	ModBus	9600	Supervision system or local mode
10	ModBus	4800	
11	ModBus	2400	
12	ModBus	1200	
13	JBus	9600	
14	JBus	4800	
15	JBus	2400	
16	JBus	1200	
17	ModBus	9600	
18	ModBus	4800	
19	ModBus	2400	
20	ModBus	1200	
21	JBus	9600	
22	JBus	4800	
23	JBus	2400	
24	JBus	1200	

**0** <sup>SV</sup> Loop A Set point Bias  
<sub>W</sub> (only if remote Set point is selected)  
 -100...200 % of span

**1.00** <sup>SV</sup> Loop A Set point Ratio  
<sub>W</sub> (only if remote Set point is selected)  
 -9.99...10.00

**0** <sup>SV</sup> Loop A minimum Y1 output  
<sub>W</sub> (not displayed if servomotor output is selected) 0...90% of output

**100** <sup>SV</sup> Loop A maximum Y1 output  
<sub>W</sub> (not displayed if servomotor output is selected) 10...100% of output

**0** <sup>SV</sup> Loop B minimum Y1 output  
<sub>W</sub> 0...90% of output

**100** <sup>SV</sup> Loop B maximum Y1 output  
<sub>W</sub> 10...100% of output

**0** <sup>SV</sup> X1 Input shift  
<sub>W</sub> -60...60% digits

**0** <sup>SV</sup> X2 Input shift  
<sub>W</sub> -60...60% digits

**0** <sup>SV</sup> Y1 output forcing value of  
<sub>W</sub> Loop A (9)  
 0...100% of output

**0** <sup>SV</sup> Y1 output safety value  
<sub>W</sub> of Loop A  
 0...100% of output

**0** <sup>SV</sup> Y2 output safety condition  
<sub>W</sub>  = Disabled  
 = Open contact  
 = Closed contact

**0** <sup>SV</sup> Y3 output safety condition  
<sub>W</sub>  = Disabled  
 = Open contact  
 = Closed contact

**0** <sup>SV</sup> Y4 output safety condition  
<sub>W</sub>  = Disabled  
 = Open contact  
 = Closed contact

**0** <sup>SV</sup> Y5 output safety condition  
<sub>W</sub>  = Disabled  
 = Open contact  
 = Closed contact

**0** <sup>SV</sup> Y1 output safety value Loop B  
<sub>W</sub> 0...100% of output

6.4 Parameters description

To simplify the use of parameters, they are grouped in homogeneous groups with the similar functions

1<sup>st</sup> GROUP

5.P. 1<sup>st</sup> memorized Set point

5.P. 2<sup>nd</sup> memorized Set point

5.P. 3<sup>rd</sup> memorized Set point

These pre-fixed Set point values can be recalled by logic inputs, keyboard or serial comm.s. The selected Set point number appears on the auxiliary display

5 l. u. Loop A Set point Slope up

5 l. d. Loop A Set point Slope down

5 l.u.b. Loop B Set point Slope up

5 l.d.b. Loop B Set point Slope down

Set point speed change (digits/min)

425.P. Y2 Alarm Set point

435.P. Y3 Alarm Set point

445.P. Y4 Alarm Set point

455.P. Y5 Alarm Set point

Set point of Y2,Y3,Y4,Y5 outputs. The alarms type depend on the relative configuration code.

42H4. Y2 hysteresis

43H4. Y3 hysteresis

44H4. Y4 hysteresis

45H4. Y5 hysteresis

Hysteresis of Y2,Y3,Y4,Y5 outputs (% of span)

Alarm types

Deviation

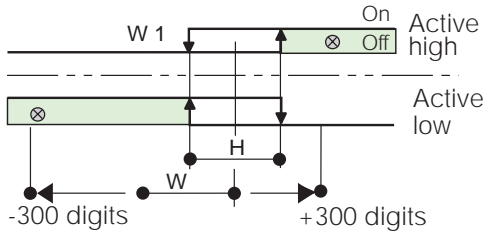

Band

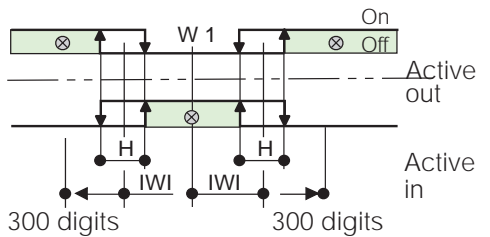

Independent

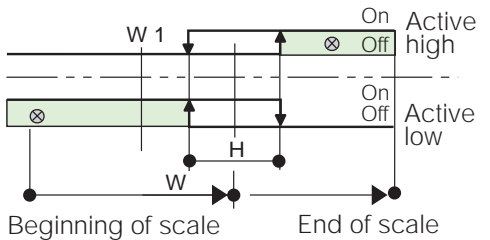

Input interruption

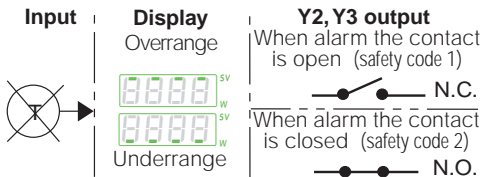

Hysteresis

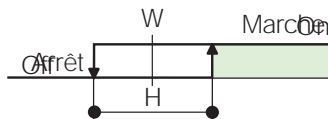

2<sup>nd</sup> GROUP

**P.b.** <sup>SV</sup><sub>W</sub> **Master or Loop A**  
**Proportional band**

**P.b. 5.** <sup>SV</sup><sub>W</sub> **Slave**  
**Proportional band**

**P.b. 6.** <sup>SV</sup><sub>W</sub> **Loop B**  
**Proportional band**

The proportional action modifies the Y1 control output value respect the deviation (W - X) in a proportional way.

**E.i.** <sup>SV</sup><sub>W</sub> **Master or Loop A**  
**Integral Time**

**E.i. 5.** <sup>SV</sup><sub>W</sub> **Slave**  
**Integral Time**

**E.i. 6.** <sup>SV</sup><sub>W</sub> **Loop B**  
**Integral Time**

This is the necessary time of the Integral action to give the same power which has already given by the proportional action

**E.d.** <sup>SV</sup><sub>W</sub> **Master or Loop A**  
**Derivative time**

**E.d. 5.** <sup>SV</sup><sub>W</sub> **Slave**  
**Derivative time**

**E.d. 6.** <sup>SV</sup><sub>W</sub> **Loop B**  
**Derivative time**

This is the necessary time of proportional action to reach the same level of P. + D. actions

**r.y.** <sup>SV</sup><sub>W</sub> **Master or Loop A**  
**Balance output shift**

**r.y. 5.** <sup>SV</sup><sub>W</sub> **Slave**  
**Balance output shift**

**r.y. 6.** <sup>SV</sup><sub>W</sub> **Loop B**  
**Balance output shift**

If **E** is Off, the Balance Output Shift corresponds to the Y1 value on steady conditions (W = X)

**F.int.** <sup>SV</sup><sub>W</sub> **Master or Loop A**  
**Fuzzy intensity**

It allows to change the strenght of Fuzzy algorithm respect the PID algorithm during the control mode

**E.c.** <sup>SV</sup><sub>W</sub> **Master or Loop A**  
**Y1 cycle time**

**E.c. C.** <sup>SV</sup><sub>W</sub> **Slave**  
**Y1 cycle time**

**E.c. 6.** <sup>SV</sup><sub>W</sub> **Loop B**  
**Y1 cycle time**

This is the basic time used by the control algorithm to change the On % value respect the Off % value of Y1 output during the control mode.

**d.b.** <sup>SV</sup><sub>W</sub> **Dead band**

Dead Band between heating/cooling control outputs.

## Heating / cooling algorithm

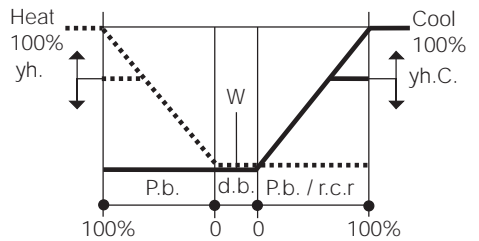

..... heat output      ——— cool output

**r.c.r.** <sup>SV</sup><sub>W</sub> **COOL Relative Gain**

This value is the ratio between the cooling/heating proportional band

**E.y.** <sup>SV</sup><sub>W</sub> **Valve stroke time**

Necessary time to go from 0 to 100% of servomotor stroke.

**d.y.** <sup>SV</sup><sub>W</sub> **Output dead zone**

Output sensitivity or output dead zone

**Pot. 1.** <sup>SV</sup><sub>W</sub> **Valve position calibration**

It allows to enter into the calibration procedure of the potentiometer position.

**H.y.** <sup>SV</sup><sub>W</sub> **Y1 hysteresis**

Hysteresis of Y1 output (% of span).

3<sup>rd</sup> GROUP

**P.b. 2.** <sup>SV</sup><sub>W</sub> **Master or Loop A**  
**2<sup>nd</sup> proportional band**

The proportional action modifies the Y1 control output value respect the deviation W-X in a proportional way.

**E.i. 2.** <sup>SV</sup><sub>W</sub> **Master or Loop A**  
**2<sup>nd</sup> Integral time**

This is the necessary time of the integral action to give the same power which has already given by the proportional action



**E.d. 2** <sup>SV</sup> **Master or Loop A**  
**2<sup>nd</sup> Derivative time**

This is the necessary time of proportional action to reach the same level of P. + D. actions

**r.9. 2** <sup>SV</sup> **Loop A**  
**balance output shift**

If **t** is Off, the Balance Output Shift corresponds to the Y1 value on steady conditions ( $W = X$ ) (When the correct PD algorithm is entered and the process has been stabilized, on off-set conditions, enter the Y1 value shown on the W/SV display).

**r.c.r. 2** <sup>SV</sup> **Master or Loop A**  
**2<sup>nd</sup> Cool Relative Gain**

This value is the ratio between the cooling/heating proportional band

#### 4<sup>th</sup> GROUP

**F.F.c.c.** <sup>SV</sup> **Fuzzy scale amplitude**

It means the % of span where the Fuzzy logic operates.

**F.d.F.c.** <sup>SV</sup> **Fuzzy derivative**

This parameter inform the Fuzzy algorithm about the maximum process speed. (% of span)

**E.S.d.r.** <sup>SV</sup> **Sampling time**

It refers to the sampling time of the controller. (sec.s)

**E.F. 1.1** <sup>SV</sup> **X1 input Time constant**

**E.F. 1.2** <sup>SV</sup> **X2 input Time constant**

Time Constant of the input RC filter applied on the process variable (X) input (sec.s).

#### Filter effects

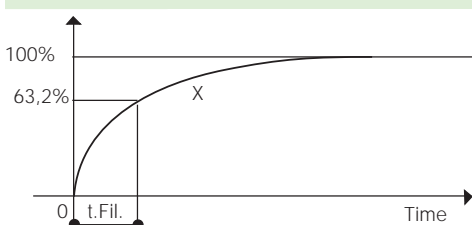

**9.5 1.w.** <sup>SV</sup> **Max speed for**  
**increasing of Y1 value**

**9.5 1.d.** <sup>SV</sup> **Max speed for**  
**decreasing of Y1 value**

It limits the increasing speed of Y1 output (output% / sec.s)

#### 5<sup>th</sup> GROUP

**A.P.a.r.** <sup>SV</sup> **Functions and**  
**Parameters protection**  
**level code** (See page 20)

**A.t.u.** <sup>SV</sup> **Auto-Tune On/Off code**

0 = Off

1 = On

If the code "0" is entered, the function does not appear in the main menu.

**S.C.1** <sup>SV</sup> **Serial comm.s code**  
(see table on V<sup>o</sup> group)

**A.d.d.r.** <sup>SV</sup> **Serial comm.s**  
**address**

The address can be selected between 1 and 247.

**S.P.L.1.** <sup>SV</sup> **Master or Loop A Scale**  
**beginning Set point**  
**lower limit**

**S.P.1.b.** <sup>SV</sup> **Loop B Scale beginning**  
**Set point lower limit**

It limits the selection of the minimum Set point value.

**S.P.L.h.** <sup>SV</sup> **Master or Loop A Full**  
**scale Set point higher limit**

**S.P.h.b.** <sup>SV</sup> **Loop B Full scale Set**  
**point higher limit**

It limits the selection of the maximum Set point value.

**S.P.r.b.** <sup>SV</sup> **Master or Loop A**  
**Remote Set point Bias**

**S.P.S.b.** <sup>SV</sup> **Slave**  
**Remote Set point Bias**

Starting point of analog remote Set point (eng. units).

**S.P.r.r.** <sup>SV</sup> **Master or Loop A**  
**Remote Set point Ratio**

**S.P.S.r.** <sup>SV</sup> **Slave Remote Set point**  
**Ratio**

It defines the remote Set point span (eng. units).



## Example

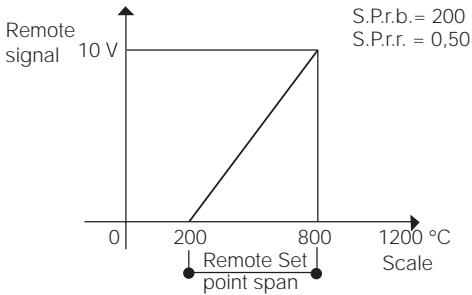

Remote Set point span = span x S.P.r.r.

**5.P.15.** <sup>SV</sup> **Slave scale beginning**  
<sub>W</sub> **Set point Lower limit**

H limits the selection of the minimum Set point value

**5.P.H.5.** <sup>SV</sup> **Slave Full scale Set**  
<sub>W</sub> **point higher limit**

H limits the maximum Set point value

**91.** <sup>SV</sup> **Master or Loop A**  
<sub>W</sub> **Minimum Y1 output**

**91.6.** <sup>SV</sup> **Loop B**  
<sub>W</sub> **Minimum Y1 output**

Minimum Y1 output value during control mode. This limit also operates in manual mode.

**96.** <sup>SV</sup> **Master or Loop A**  
<sub>W</sub> **Maximum Y1 output**

**96.6.** <sup>SV</sup> **Loop B**  
<sub>W</sub> **Maximum Y1 output**

Maximum Y1 output value during control mode. This limit also operates in manual mode.

**96.0.** <sup>SV</sup> **Master or Loop A**  
<sub>W</sub> **Maximum Y1 output**

Maximum "cool" Y1 output value during the heating / cooling control mode. This limit also operates in manual mode.

**10.56.** <sup>SV</sup> **X1 Input shift**  
<sub>W</sub>

**10.52.** <sup>SV</sup> **X2 Input shift**  
<sub>W</sub>

This function allows to shift the scale range within  $\pm 60$  digits.

**91Pc.** <sup>SV</sup> **Y1 Output forcing value**  
<sub>W</sub>

Controller forces Y1 output to the selected value when the corresponding Logic input is active

**52.91.** <sup>SV</sup> **Master or Loop A**  
<sub>W</sub> **Y1 output safety value**

**52.96.** <sup>SV</sup> **Loop B**  
<sub>W</sub> **Y1 output safety value**

Controller forces the Y1 to the selected value in the under/overrange conditions

**52.92.** <sup>SV</sup> **Y2 output safety**  
<sub>W</sub> **condition**

**52.93.** <sup>SV</sup> **Y3 output safety**  
<sub>W</sub> **condition**

**52.94.** <sup>SV</sup> **Y4 output safety**  
<sub>W</sub> **condition**

**52.95.** <sup>SV</sup> **Y5 output safety**  
<sub>W</sub> **condition**

Controller forces the Y2 , Y3 , Y4 and Y5 alarms to the selected conditions in the under/overrange conditions (see table page 19)

## Keys and displays functions

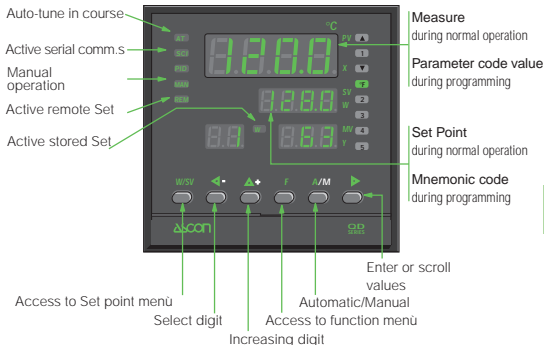

## 7.0• Function menu

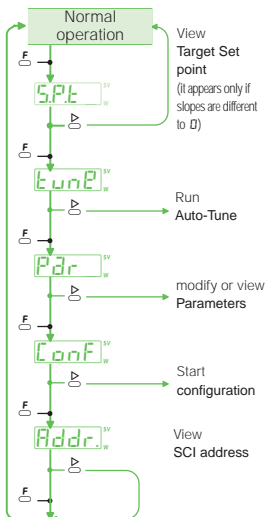

## 7.1• Modification of a numeric field

It is possible to modify any numeric field by changing each digit in turn.

Example: to change 250 to 260

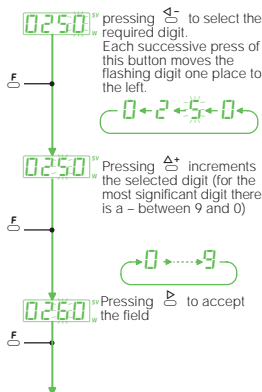

## 7.2•

## Menu Set point

### 7.2.1•

Local only

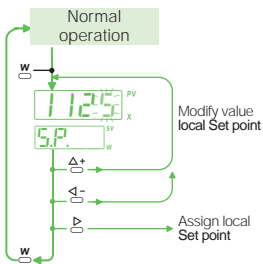

0,3

### 7.2.2•

Local +3 memorized Set

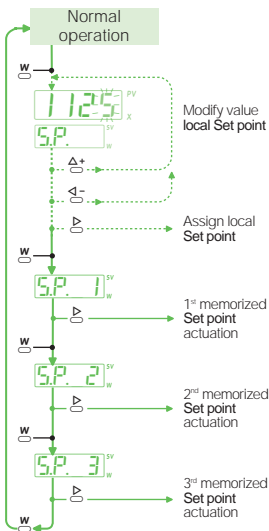

## 7.3•

## Auto Man

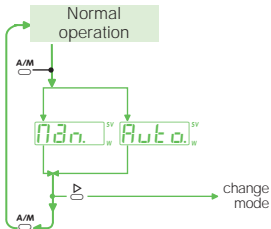
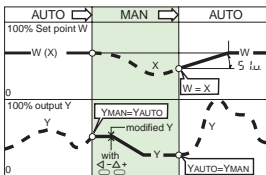

## Menu Set point

7.2.3•

Local + Remote

Note

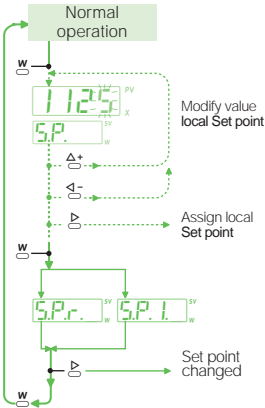

### Note:

After the Set point has been modified the new target Set point will be reached after a period of time, depending upon the values entered in the  $5L_u$  (Slope up) and  $5L_d$  (Slope down) gradient parameters.

### Example:

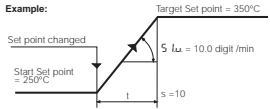

If slope gradient is equal to zero there will be a step change

When Remote Set point we suggest, to set  $5L_u$  and/or  $5L_d$  to 0 (zero)

The new Set point value which must be reached, it is called "target Set point". It appears under  $SP.t$  code during the main menu scrolling.

7.4•

## Auto Tune

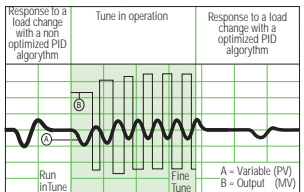
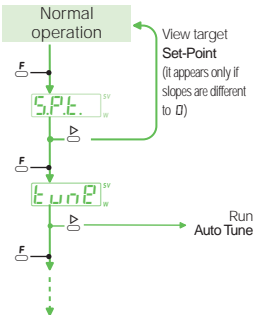

**7.5• Page Scrolling**

**7.5.2• Cascade Loop**

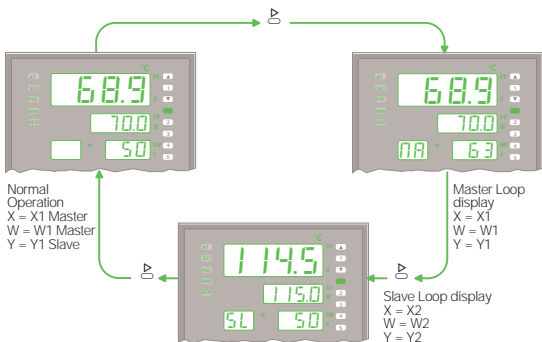

**7.5.2• Ratio Loop**

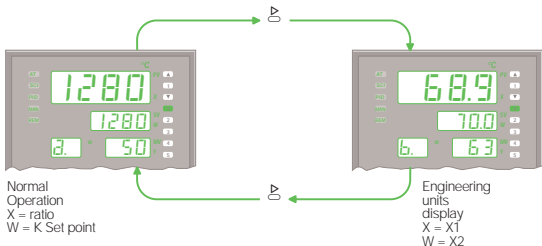

**7.5.3• 2 Independent Loops**

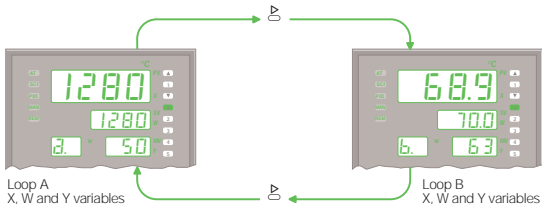

Features at env. 25°C	Description			
<b>Total configurability</b>	From the keyboard or serial line, with a guided menu, you can choose, in sequence: type of control, operational mode, inputs, outputs, Set points and insert all control parameters.			
<b>Operational mode</b>	1 Loop with single/double output			
	1 Cascade loop (1 Master + 1 Slave)			
	1 ratio loop 1 Independent loops			
<b>Control mode</b>	Algorithm	On-Off, P.I.D., PID + FUZZY and PID " with "three point stepping" output		
	Proportional Band (P)	0.5...999.9%		
	Integral time (I)	0.0...100.0 min	Excludable with 0	
	Derivative time (D)	0.00...10.00 min		
	FUZZY intensity	0.0...90.0%		
	Balance output shift	0...100%	For P. and P.D. algorithm	
	Cycle time	1...200 sec.	For discontinuous output	
	Hysteresis	0.01...10.00%	For On-Off algorithm	
	Dead zone	0.0...5.0%	For PID algorithm to double action (heat-cool)	
	Cool Relative gain	0.1...3.0		
	Valve stroke time	15...600 sec	For servomotors output	
	Output dead zone	0.1...10.0%		
Potentiometer	100Ω...10KΩ			
<b>Input measure X1</b> (see page 17)	Common characteristics	A/D converter with 50.000 points Sampling time: 0.5 to 30.0 sec. configurable Input shift: -60...+60 digits Input filter: 0...30 sec.s (excludable)		
	Accuracy	0.2% ± 1 digit (T/C, RTD) 0.1% ± 1 digit (mA e V)	Between 100...240Vac, error is irrelevant	
	Thermoresistance	Pt100Ω a 0 °C (IEC 751) With °C/°F/°K selection	2 or 3 wires connections	Line: 20Ω max (3 wires) Thermal drift: 0.1°C/10°C env. T. <0.5°C/10Ω line R.
	Thermocouple	L,J,T,K,R,S,B,N,E,W (IEC 548) With °C/°F/°K selection	Internal or external cold joint compensation in °C/°F/K	Line: 150Ω max Thermal drift: <2μV/°C env. T. <5μV/10Ω line R.
	Continuous current	4...20mA, 0-20mA Ri=30Ω	Engineering units, floating point, with or without sq.rt. extraction	Input drift: <0.1%/20°C env. T.
Continuous voltage	0-20mV, 0-50mV Ri=10 MΩ 0-1/1-5/0-5/0-10V Ri=10kΩ	L.R. -999...9999 H.R. -999...9999 (min 100 digits)		
<b>Auxiliary inputs</b>	3 of logic type	Permanent closure of external associated allow:	Auto/Man switching, local/Remote Set point selection, recall of 3 stored Set points, keyboard lock. 2 <sup>nd</sup> PID algorithm, Y1 = Remote Set point Y1 = forcing value	
<b>Main output Y1</b>	Single or double, with direct or reverse action			
	Lower limit	0...90%(channel ▲)		
	Higher limit	100...10% (channel ▲) -100...-10% (channel ▼)		
	Safety value	0...100%,-100...100% (for double output)		
	Forcing value	0...100%,-100...100% (for double output) from Logic input		
	Discontinuous	Double action relay, 2 contacts NA, 5A/250Vac, 2x10 <sup>5</sup> transitions		
		Logic	0-22Vdc, 20mA max for solid state relay	Galvanically isolated: 500 Vac/1min Protect to c.c.
	Continuous	Current	0-20mA, 4-20mA 750Ω/15Vdc max	Galvanically isolated: 500 Vac/1min Protect to c.c.
Voltage		1-5V,0,5V,0-10V 500Ω/20mA max	Resol.: 12 bit (0.025%) Accuracy: 0.1%	
"Three Point Stepping"		Double action relay 2 Contats NO, 5A/250Vac, 2 x 10 <sup>5</sup> transitions		

Features at env. 25°C	Description			
<b>Y2-Y3-Y4-Y5 auxiliary outputs</b>	Relay with contact NO, 5A/250Vac, 2x10 <sup>5</sup> transitions - Hysteresis 0,01...10,00%			
	Action mode	Active high	action type	
		Active low		
			Deviation Set point	± 300 digits
			Band Set point	0...300 digits
		Independent Set point	from Beginning to Full sc.	
		Set point to Y1	0...100%	
Safety state		enabled or not enabled with NO or NC contact		
<b>Y6 auxiliary analogic output (option)</b>	Galvanically isolated: 500Vac/1 min Protected by s.c. 12 bit (0.025%) Tolerance: 0.1%	In current: 0-20mA, 4-20mA 750Ω/15V max	Measure X retransmission	
		In voltage: 1-5V, 0-5V, 0-10V 500Ω/20mA max	Set point W retransmission	
			Y1 output (channel ▲) retransmission	
			Y1 output (channel ▼) retransmission	
			Error retransmission	0...25% of range
<b>Set point</b>	Up or down ramp can be set in digits/min. between 0.0...10.0% of the range		Local only	
	Limits: lower to upper can be set separately within the range		Local and 3 memorized	
			Remote only	
			Local and Remote	
			Local+(Local and Remote)	
<b>Remote Set point</b>	Non isolated Accuracy 0.1%	Current: 0-20mA, 4-20mA Ri = 30Ω	Bias in engineering units (-100% + 200%) (compatible with display)	
		Voltage: 1-5V, 0-5V, 0-10V Ri = 300 kΩ		
			Ratio from -9.99...+ 10.00	
			Sum Local Set point + Remote Set point	
<b>Auto-tune</b>	With "Natural Frequency", method, Tuning can occur at a Set point change or during process steady conditions, with launch enabling index.			
<b>Auto-Man station</b>	Incorporated, with Bumpless action Auto-Man transfer via keyboard, logic input and serial communications			
<b>Serial Comm.s (option)</b>	RS 485, Modbus, Jbus protocol, 1200,2400,4800,9600 bit/sec., 2 wires (read only or read write or supervision system local mode)			
<b>Auxiliary power supply</b>	24 Vdc ± 10%, 50 mA max Up to 2 external transmitters (2, 3 or 4 wire connections)			
<b>Operational security</b>	Main input	Out of range or hardware failure (short or open circuit) is monitored and the outputs are forced to security values		
	Control output	Settable security value: 0...100%, -100...+100% (for double action)		
	Auxiliary outputs	Security status can be configured: excluded, NO or NC		
	Parameters	All parameters values are saved for unlimited time in non volatile memory. Subdivided into 4 homogeneous groups, configurable as: visible and modifiable, visible or not modifiable, invisible.		
<b>General features</b>	Access keys	"Password" for accessing the V° group of parameters, to programming parameters for the Set point and for the configuration..		
	Power supply	100...240V, 50/60 Hz, -15...+10% (250 Vac max) or 16...28V, 50/60 Hz e 20...30Vdc Absorbed power 5VA max		
	Electric safety	EN61010, installation category II° (2500V), pollution level 2		
	Electromagnetic compatibility	According to norms required for CE brand for systems and industrial apparatus		
	Environmental	KWF according to DIN 40040, working ambient temperature 0...50°C		
	Protection according to DIN40050	P 20 (terminal block), P 30(case), IP54 (front panel) or IP67 con kit F10-435-2A101, material guard UL 94 V1		
	Dimensions:	96 x 96 DIN, depth: 154.5 mm, weight: 0.8 kg appr.		

The equipment is guaranteed free from manufacturing defects for 1 year after installation, for a maximum of 18 month after delivery.

Faults caused by use other than that described in the operating instructions are excluded from the guarantee.

**CE conformity****E**

We declare that this instrument is in conformity with the following Standards for Industrial environment:

- |            |  |
|------------|--|
| EN 50081-2 | Electromagnetic compatibility<br>Generic emission standard |
| EN 50082-2 | Electromagnetic compatibility<br>Generic immunity standard |
| EN 61010   | General safety requirements<br>for electrical equipments   |