



ET1-

ELECTRONIC CONTROLLER FOR REFRIGERANT UNITS



OPERATING INSTRUCTIONS



DIFFUSION Service

TOUTE LA RÉGULATION

REGULATION - MESURE - INSTRUMENTATION - AUTOMATISME
www.diffusion-service.fr - 02.51.65.99.99 - info@diffusion-service.fr
Z.A.E du Moulin - 3 rue Marie CURIE - 85130 CHANVERRIE

Index

1. Instrument description.....	1
1.1 General description	1
1.2 Front panel description	2
2. Programming	2
2.1 Fast Set point programming	2
2.2 Standard parameter programming.....	2
3. Usage warnings	3
3.1 Admitted use	3
4. Installation warnings.....	3
4.1 Mechanical mounting	3
4.2 Dimensions [mm].....	3
4.3 Electrical connections.....	4
5. Functions.....	4
5.1 ON/Stand-by function	4
5.2 Normal and economic operation.....	4
5.3 Measure configuration	4
5.5 Temperature control.....	5
5.6 Compressor protection function and power-ON delay	5
5.7 Defrost control.....	5
5.8 Alarm functions	6
6. Accessories.....	6
6.1 Parameters configuration by A01.....	6
6.2 Parameters configuration by AFC1	6
7. Programmable parameters table	7
8. Maintenance	7
8.1 Cleaning.....	7
8.2 Disposal	7
9. Warranty and Repairs.....	7
10. Technical data	7
10.1 Electrical characteristics	7
10.2 Mechanical characteristics.....	8
10.3 Functional features.....	8
11. How to order	8

PREFACE

This manual contains the information necessary for the product to be installed correctly and also instructions for its maintenance and use; we therefore recommend that the utmost attention is paid to the following instructions and to save it.

This document is the exclusive property of Ascon Tecnologic S.r.l. which forbids any reproduction and divulgation, even partially, of the document, unless expressly authorized. Ascon Tecnologic S.r.l. reserves the right to make any formal or functional changes at any moment and without any notice. Ascon Tecnologic S.r.l. and its legal representatives do not assume any responsibility for any damage to people, things or animals deriving from violation, wrong or improper use or in any case not in compliance with the instrument features.

Whenever a failure or a malfunction of the device may cause dangerous situations for persons, thing or animals, please remember that the plant has to be equipped with additional electromechanical devices which will guarantee safety.

1. INSTRUMENT DESCRIPTION

1.1 General description

Model **ET1** is a **digital electronic microprocessor controller** that can be used for **cooling applications**. It has **temperature control with ON/OFF action** and **defrosts control at time intervals**, for **reaching temperature** or for **continuous compressor operation** through stopping the compressor.

The instrument has **1 relay output**, **1 temperature probe NTC input** and **a digital input**.

The **temperature Set Point** is set using the **knob** while the **operating parameters** can be programmed **via the A01 device** connected to the **TTL port** (standard) or via **NFC communication** (optional).

1.2 Front panel description

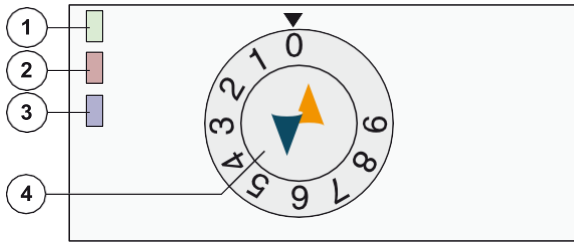

- 1 **Led 1 (GREEN):** Shows the instrument status:
ON = Instrument in Eco mode;
Flashing = Instrument in Normal mode.
- 2 **Led 2 (RED):** Indicates the status Alarm/Standby:
ON = Powered, but in standby status;
Flashing = Alarm active.
- 3 **Led 3 (BLU):** Specifies the control status:
ON = Control actuator (compressor) ON;
Flashing = Defrost in progress.
- 4 **Set Point setting knob:** The knob is used to manage the control Set Point. The knob acts on a trimmer with 10 snap positions. Position **0** matches the higher Set Point value ($S.HS$) when $t.UF = 0F$; while, when $t.UF = 1$, it matches the Standby status. Position **9** matches the lower Set Point value ($S.LS$).

2. PROGRAMMING

2.1 Fast Set point programming

The Set Point is set using the instrument knob.

Setting parameter $t.UF = 0F$, position **0** corresponds to the higher Set Point value ($S.HS$) while position **9** corresponds to the lower Set Point value ($S.LS$). In this way, the Set Point values are calculated (with approximation) as follows:

Position	Set Point value	Example
0	= $S.HS$	14
1	SLS + $\frac{ S.HS - S.LS }{9}$	-8 12
2	SLS + $\frac{ S.HS - S.LS }{9}$	-7 10
3	SLS + $\frac{ S.HS - S.LS }{9}$	-6 8
4	SLS + $\frac{ S.HS - S.LS }{9}$	-5 6
5	SLS + $\frac{ S.HS - S.LS }{9}$	-4 4
6	SLS + $\frac{ S.HS - S.LS }{9}$	-3 2
7	SLS + $\frac{ S.HS - S.LS }{9}$	-2 0
8	SLS + $\frac{ S.HS - S.LS }{9}$	-2
9	= $S.LS$	-4

When instead $t.UF = 1$, position **0** corresponds to the **Standby** status (control disabled), position **1** corresponds to the **higher Set Point** ($S.HS$) while position **9** corresponds to the lower Set Point value ($S.LS$).

In this way, the Set Point values are calculated (with approximation) as follows:

Position	Set Point value	Example
0	Standby Mode (control is OFF)	-
1	= $S.HS$	14
2	SLS + $\frac{ S.HS - S.LS }{8}$	-7 11.8
3	SLS + $\frac{ S.HS - S.LS }{8}$	-6 9.5
4	SLS + $\frac{ S.HS - S.LS }{8}$	-5 7.3
5	SLS + $\frac{ S.HS - S.LS }{8}$	-4 5
6	SLS + $\frac{ S.HS - S.LS }{8}$	-3 2,8
7	SLS + $\frac{ S.HS - S.LS }{8}$	-2 0.5
8	SLS + $\frac{ S.HS - S.LS }{8}$	-1.8
9	= $S.LS$	-4

2.2 Standard parameter programming

Parameters are programmed using a Personal Computer and the **AT Universal Config** program.

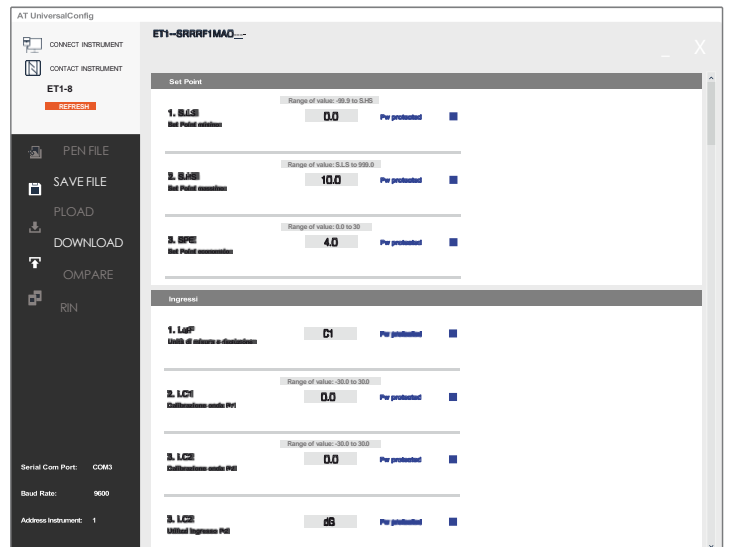

The transmission of the parameter configuration to the instrument can take place via the **TTL communication port** and the **A01 device** or, if the instrument is equipped with the **optional NFC communication**, by means of the **AFC1 device**. The A01 and AFC1 devices are connected to the PC via a common **USB port**.

More information on **how to install** and **use** the *AT Universal Config* program can be found in the *AT Universal Config User manual*.

2.2.1 Programming the instrument with A01 device

The **A01 device** it is mainly usable for the serial programming of some instruments which need to have the same parameters configuration or to keep a copy of the parameters setting of an instrument and allow its rapid retransmission.

The same device allows to connect a PC via USB with which, through the appropriate configuration software for "*AT UniversalConf*" tools, the operating parameters can be configured.

For the instrument configuration with the A01 device it is necessary that the A01 is powered with the specific

power supply and that **the instrument is disconnected from the mains as there is no insulation between power supply and TTL connector.**

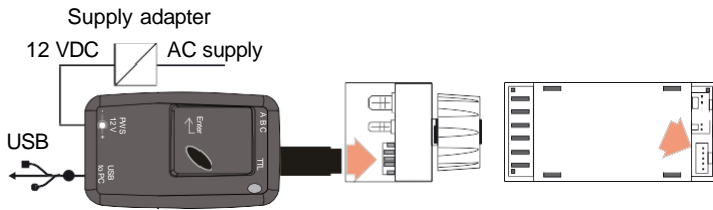

2.2.2 Programming the instrument with AFC1 device

To configure the instrument with the AFC1 device, the instrument must be placed on the side indicated with the appropriate symbol on the AFC1 device, which is powered directly by the USB port connected to the PC.

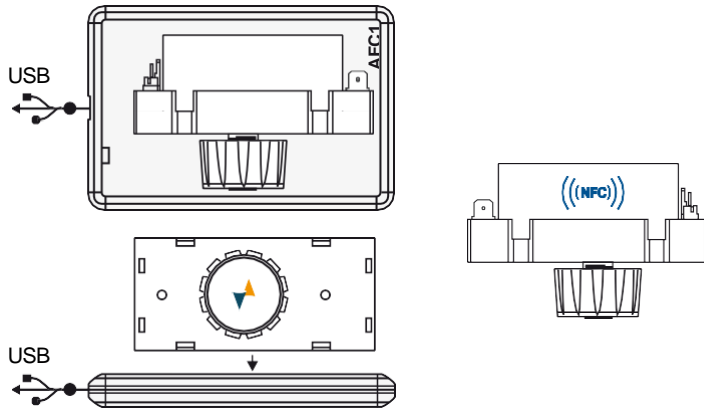

3. USAGE WARNINGS

3.1 Admitted use

The instrument has been projected and manufactured as a measuring and control device to be used according to EN60730-1 at altitudes operation below 2000 m.

Using the instrument for applications not expressly permitted by the above mentioned rule must adopt all the necessary protective measures.

This instrument employs sealed relays conforming to IEC/EN 60079-15, tested for use in refrigerators and freezers that are using flammable refrigerant gases.

The instrument **MUST NOT BE USED** in dangerous environments (flammable or explosive) without adequate protections.

There is NO INSULATION between power supply and inputs, therefore, if the probe and/or the digital input are accessible, they must be of the double insulation type (Class II insulation).

The installer must ensure that the EMC rules are respected, also after the instrument installation, if necessary using proper filters.

4. INSTALLATION WARNINGS

4.1 Mechanical mounting

The instrument is designed for panel mounting within an enclosure.

Drill a $\varnothing 10.5$ mm hole and fix the instrument with the given M10 nut or drill 2 holes at the indicated distance and use 2 $\varnothing 3.2$ self-threading screws having the correct length.

Avoid placing the instrument in environments with very high humidity levels or dirt that may create condensation or intro-

duction of conductive substances into the instrument. Ensure adequate ventilation to the instrument and avoid installation in containers that house devices which may overheat or which may cause the instrument to function at a higher temperature than the one permitted and declared. Connect the instrument as far away as possible from sources of electromagnetic disturbances such as motors, power relays, relays, solenoid valves, etc..

4.2 Dimensions [mm]

4.2.1 Mechanical dimensions, drilling and fixing

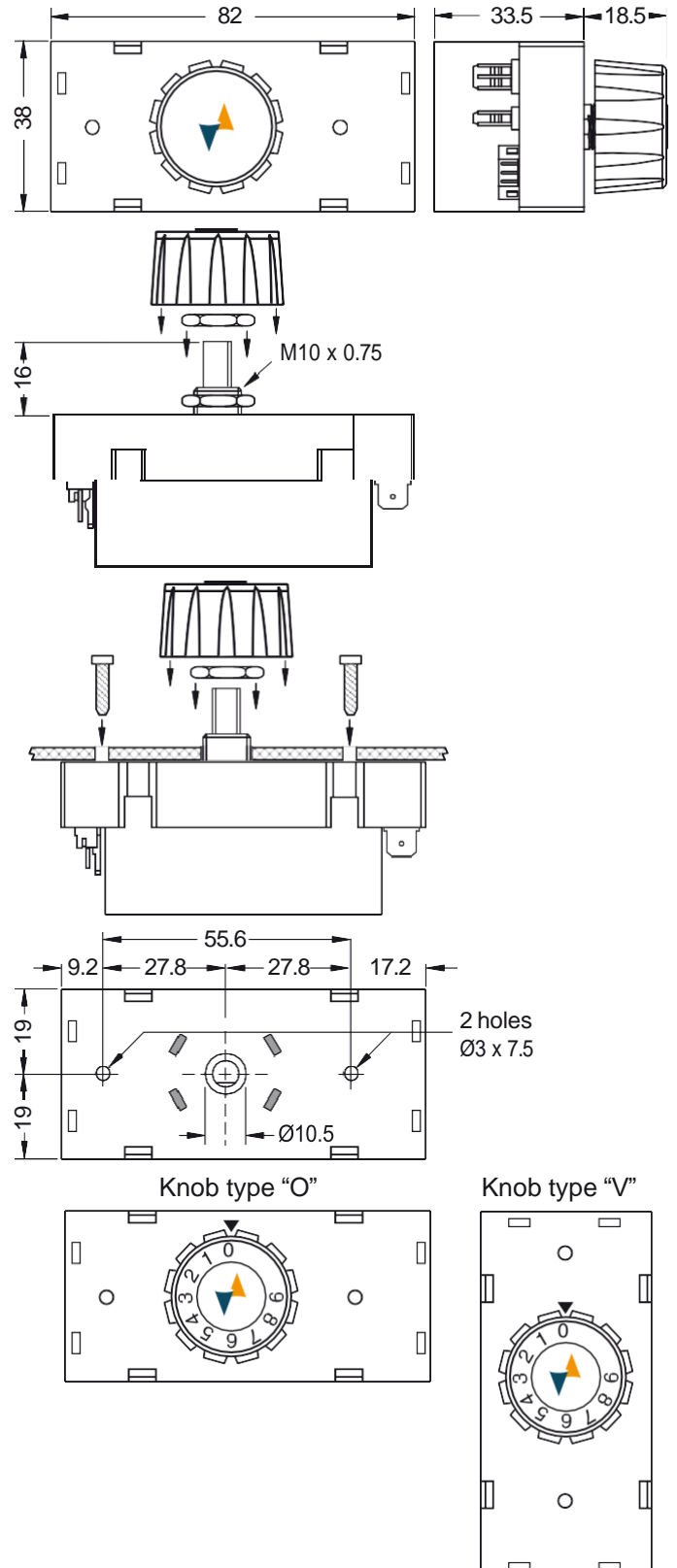

4.3 Electrical connections

Carry out the electrical wiring by connecting only one wire to each terminal, according to the following diagram, checking that the power supply is the same as that indicated on the instrument and that the load current absorption is no higher than the maximum electricity current permitted.

As the instrument is built-in equipment with permanent connection inside housing, it is not equipped with either switches or internal devices to protect against current overloads: the installation will include an overload protection and a two-phase circuit-breaker, placed as near as possible to the instrument and located in a position that can easily be reached by the user and marked as instrument disconnecting device which interrupts the power supply to the equipment

It is also recommended that the supply of all the electrical circuits connected to the instrument must be protected properly, using devices (ex. fuses) proportionate to the circulating currents. It is strongly recommended that cables with proper insulation, according to the working voltages and temperatures, be used. Furthermore, the input cable of the probe has to be kept separate from line voltage wiring. If the input cable of the probe is screened, it has to be connected to the ground at only one side.

We strongly recommend that a check should be made that the parameters are those desired and that the application functions correctly **before connecting the outputs to the actuators** so as to avoid malfunctioning that may cause irregularities in the plant that could cause damage to people, things or animals.

4.3.1 Electrical wiring diagram

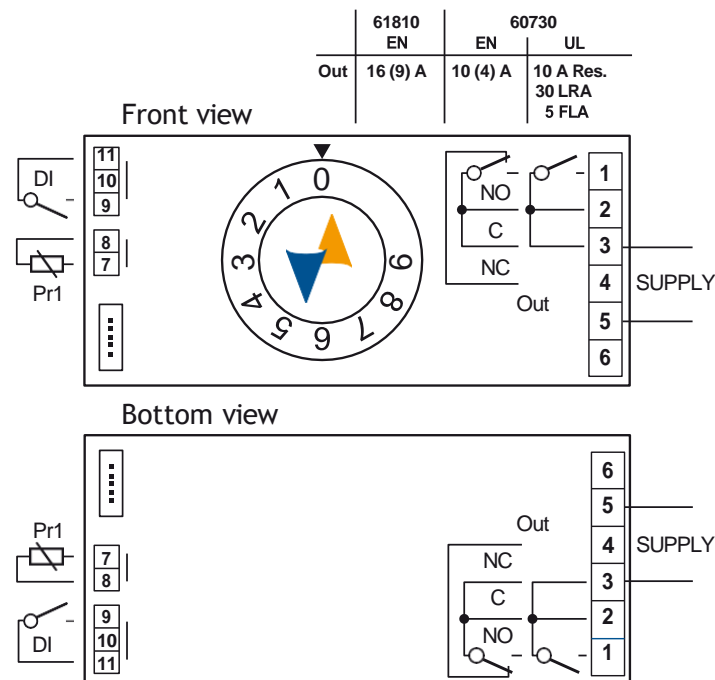

5. FUNCTIONS

5.1 ON/Stand-y function

Setting parameter $t.UF = 1$ it is possible to force the instrument in Standby mode when the knob in position **0**.

When in Standby mode the instrument implements no control function, the status is signalled by the green LED ON.

When $t.UF = 0F$ (or $t.UF = 1$ but with the knob is in a position different than **0**), the instrument is in **ON** state and applies all the control functions. The ON status is signaled by the flashing green LED.

5.2 Normal and economic operation

The instrument normally operates the control according to the temperature set by the knob and as a function of the differential of intervention (hysteresis) set at parameter $r.d$.

However, using the properly configured digital input, it is possible to increase the operating Set Point by the value set at parameter SPE parameter and to operate with the differential of intervention set at $r.Ed$.

Switching between the two modes [defined *Normal* and *Economic (Eco)*] can be automatic or manual and can be used when is necessary to switch between 2 operating temperatures (e.g. day/night or weekday/holiday).

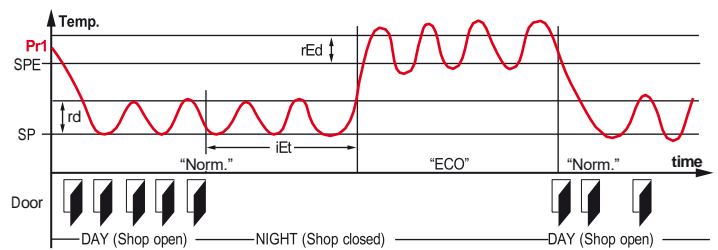

The *Normal/Economic* mode can be selected automatically or manually via the digital input when $i.Fi = 6$:

- After the time $i.et$ has elapsed after the door has been closed (switching from *Normal* to *Eco*);
 - When opening the door if the *Eco* mode is active (switching from *Eco* to *Normal*);
 - After the time $i.tt$ has elapsed from closing the door and the activation of the *Eco* mode (switching from *Normal* to *Eco*);
- To enable this function is necessary to set the digital input as $i.Fi = 1, 2$ or 3 .

If $i.Et = 0F$ the switching between *Normal/Eco* mode through the digital input configured as *door* is **disabled**.

If $i.tt = 0F$ the switching between *Normal/Eco* mode through a *time-out* is **disabled**.

5.3 Measure configuration

With $i.uP$ it is possible to select the temperature engineering unit (**C0, C1** = °C; **F0, F1** = °F).

The instrument allows the measure calibration, which can be used to recalibrate the instrument according to application needs, the calibration is made with parameter $i.C1$.

5.4 Digital input configuration

The digital input function is defined using the iFi parameter and the action is delayed for the time programmed with parameter iti . The iFi parameter can be configured for the following functions:

- 0 **Digital input not active;**
 - 1 **Cell door opening with NO contact:** at input closure (and after the iti) the instrument senses the door opening, activates the time set with parameter AoA elapsed which the alarm is activated to warn that the door has been left open. In addition, at door opening, the instrument returns to Normal operation if it was in Eco mode (Eco mode enabled through parameter iEt);
 - 2 Similar to $iFi = 1$;
 - 3 **Cell door opening with compressor lock and NO contact:** similar to $iFi = 1$ but with compressor lock. At open door alarm intervention (AoA) also the compressor is re-activated;
 - 4 **External alarm signal with NO contact:** at input closing (and after the iti time) the instrument activates an alarm;
 - 5 **External alarm signal with control output disabled and NO contact:** at input closing (and after the iti time) the control output is disabled and the alarm is activated;
 - 6 **Normal/Economic mode selection with NO contact:** at input Closing (and after the iti time) the instrument switches to *Eco* operation mode. Opening the digital input, the instrument returns in *Normal* operation mode;
 - 7 **Instrument On/Off (stand-by) selection with NO contact:** at input Closing (and after the iti time) the instrument is switched ON. Opening the digital input, the instrument is placed in Stand-by mode;
 - 8 Do not use;
- 1, -2, -3, etc. - Features identical to the above but obtained through a NC contact and a reversed logic operation.

5.5 Temperature control

The instrument control is **ON/OFF** and acts on the output depending on the PR1 probe measuring, the Set Point SP (or SPE) and the Hysteresis rd (or rEd).

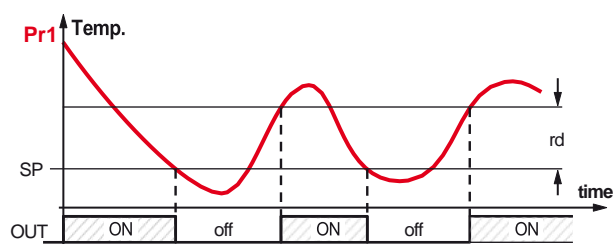

In the event of a probe error, it is possible to set the instrument so that the output continues working in cycles according to the times programmed with parameter $rt1$ (activation time) and $rt2$ (deactivation time).

If an error occurs on the probe the instrument activates the output for the time $rt1$, then deactivates it for the time $rt2$ and so on whilst the error remains.

Programming $rt1 = oF$ the output in probe error condition remains switched OFF.

Programming instead $rt1$ to any value and $rt2 = oF$ the output in probe error condition remains switched ON.

Remember that the temperature regulation function can be conditioned by the *Compressor Protections*, *Delay at power ON*, *Defrost functions*, *Door open* and *External Alarm with output Lock* through Digital Input.

5.6 Compressor protection function and power-ON delay

The “**Compressor Protection**” function aims to avoid repeated compressor start-ups controlled by the instrument in cooling applications or otherwise can be used to add a timed control on the actuator control output.

This function foresees 3 time controls on the switching ON of the output associated with the temperature control request. The protection consists of preventing the output being switched ON during the times set with parameters $P.P1$, $P.P2$ and $P.P3$ and therefore that any activation occurs only after all times are elapsed.

- 1 First control (parameter $P.P1$) foresees a delay to output activation (switching-ON delay).

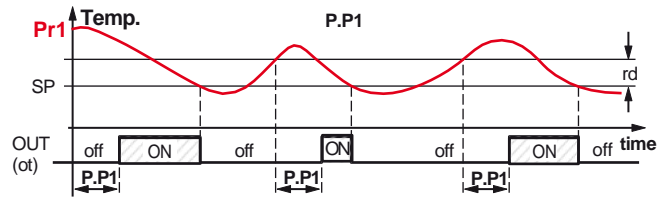

- 2 Second control (parameter $P.P2$) foresees an inhibition to the activation of the output by a delay that starts when the output is turned OFF (delay after switching-OFF or minimum power OFF time).

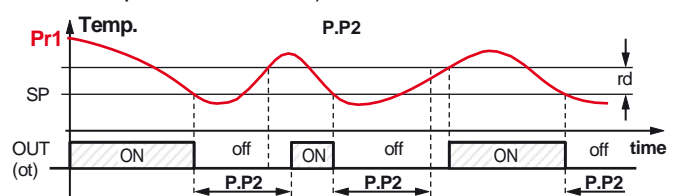

- 3 Third control (parameter $P.P3$) foresees an inhibition to output activation by a delay that starts when the output was turned ON last time (delay between two switching-ON).

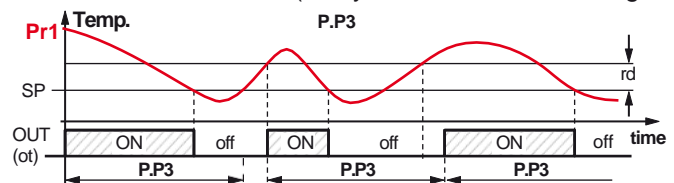

It is also possible to prevent activation of the output after the instrument is turned ON, for the time set at parameter $P.oD$. All these functions are disabled if the relative parameters are set to **OFF** (oF).

5.7 Defrost control

The automatic defrost control is made with the *stopping compressor* method; it occurs by interval times or after a certain time of continuous compressor functioning.

The automatic defrost function is activated when at parameter ddi is set the defrost interval time between 2 defrost cycles. The first defrost after power ON can be set by parameter dSd . This allows to perform the first defrost at an interval different than the ddi time.

If the instrument must perform a defrost cycle all the time it is powered ON, the parameter dSd must be set to **oF**.

If all defrost cycles must be performed after the same interval time, program $dSd = ddi$.

Automatic defrost function is totally disabled when $ddi = oF$ (including the first, regardless the time set at dSd parameter). The instrument provides to switch OFF the output for the

ddE period of time every time expires the ddi time (or dSd in case of first defrost after power ON).

The instrument then deactivates the compressor output at each expiration of the ddi time (dSd for the first defrost after instrument power ON) for the time set in dde.

Moreover, the instrument starts a defrost cycle when the compressor is activated continuously for the time dcd.

This function is used as the continuous operation of the compressor for a long period is normally a symptom of a low heat exchange typically caused by the frost on the evaporator.

5.8 Alarm functions

The alarm conditions of the instrument are:

- Probe errors E1, -E1;
- External alarm AL;
- Door open oP;
- Power supply alarms HU, LU.

Any active alarm condition is pointed out by turning on the Alarm LED (flashing red).

5.8.1 External alarm from digital input

The instrument can signal an alarm external to the instrument by activating the digital input with a function programmed as (iFi = 4 or 5). The instrument signals the alarm turning ON the alarm LED.

Mode iFi = 4 operates no action on the control output, while iFi = 5 deactivates the control output at digital input intervention.

5.8.2 Open door alarm

The instrument can sense the open door condition using the digital input setting iFi = 1, 2 and 3. As the Digital input is activated, the instrument waits for the delay set at parameter AOA, then signals that the door is open by flashing with the red alarm LED. At the open door alarm intervention is also re-activated, if inhibited, the compressor output.

5.8.3 Mains voltage alarms

The instrument can automatically deactivate the control output when the mains voltage, measured by the instrument through its power supply, is lower or higher than the values set to the parameters:

- U.LU Undervoltage alarm (expressed in Vx10);
- U.HU Overvoltage alarm (expressed in Vx10).

At alarm activation, and once the delay set at parameter U.Ud, the instrument disables the control output and signals the alarm by flashing with the red LED.

In the case that the voltage measurement results NOT correct, it can be changed with an offset that can be set using the U.OU parameter.

6. ACCESSORIES

6.1 Parameters configuration by A01

The instrument is equipped with a connector that allows the transfer from and toward the instrument of the functioning parameters through the device A01 with 5 poles connector.



For additional info, please have a look at the **A01 instruction manual**.

6.2 Parameters configuration by AFC1

The **AFC1** is a contactless **NFC** (Near Field Communications) connection device. It is able to transfer the data of the configuration program from the Personal Computer to the controller and vice versa simply by placing the instrument directly on the AFC1 device.



To configure the instrument with the **AFC1** device, the instrument must be placed on the side indicated with the appropriate symbol on the AFC1 device, which is powered directly by the USB port connected to the PC.

7. PROGRAMMABLE PARAMETERS TABLE

Here below is a description of all the parameters available on the instrument. Some of them may not be present, either due to the fact they depend on the type of instrument or because they are automatically disabled as unnecessary.

Param.	Description	Range	Def.	Note
1	SLS Minimum Set Point	-99.9 ÷ S.HS	0.0	
2	SHS Maximum Set Point	S.LS ÷ 999.0	10	
3	SPE Set Point Eco	0.0 ÷ 30.0 (°C/°F)	4.0	
4	i.uP Measurement Temperature unit	C0, C1 = °C, resolution 1°; F0, F1 = °F resolution 1°.	C0	
5	i.c1 Pr1 probe calibration	-30.0 ÷ +30.0°C/°F	0.0	
6	i.Fi Function and logic functioning of the Digital Input (adding the "-" minus sign the logic is inverted)	0 No function; 1, 2 Open Door; 3 Open Door with Output Lock; 4 External Alarm; 5 External alarm with Output Lock; 6 Normal/Eco mode select; 7 ON/Stand by mode select; 8 Not to be used.	2	
7	i.ti Digital Input Delay	oF Function disabled; 0.01 ÷ 99.59 (min.s).	oF	
8	i.Et Eco Mode activation delay at Door closed	oF Function disabled; 0.01 ÷ 99.59 (h.min).	oF	
9	i.tt Max. time functioning in Eco Mode	oF Function disabled; 0.01 ÷ 99.59 (h.min).	oF	
10	r.d Differential (Hysteresis) in Normal mode	0.0 ÷ 30.0°C/°F	2.0	
11	r.Ed Differential (Hysteresis) in Eco mode	0.0 ÷ 30.0°C/°F	2.0	
12	r.t1 Output activation time for Pr1 probe error	oF Function disabled; 0.01 ÷ 99.59 (min.s).	oF	
13	r.t2 Output deactivation time for Pr1 probe error	oF Function disabled; 0.01 ÷ 99.59 (min.s).	oF	
14	d.cd Defrost activation time for continuous compressor operating	oF Function disabled; 0.01 ÷ 99.59 (h.min).	oF	
15	d.de Defrost duration	oF Function disabled; 0.01 ÷ 99.59 (min.s).	oF	
16	d.di Defrosting interval	oF Function disabled; 0.01 ÷ 99.59 (h.min).	oF	
17	d.Sd First defrost delay after power-on	oF At Power ON; 0.01 ÷ 99.59 (h.min).	oF	
18	P.p1 Out delay at switching ON	oF Function disabled; 0.01 ÷ 99.59 (min.s).	oF	
19	PP2 Out delay after switching OFF	oF Function disabled; 0.01 ÷ 99.59 (min.s).	oF	
20	PP3 Delay between two output switching ON	oF Function disabled; 0.01 ÷ 99.59 (min.s).	oF	
21	P.od Output delay at power ON	oF Function disabled; 0.01 ÷ 99.59 (min.s).	oF	
22	A.oA Open door delay	oF Function disabled; 0.01 ÷ 99.59 (min.s).	3.00	
23	tUF Enable Stand-by when the knob is at minimal position	oF No; 1 Stand by enabled.	oF	
24	U.LU Undervoltage alarm	oF Function disabled; 9 ÷ 27 (V x 10)	oF	
25	U.HU Overvoltage alarm	oF Function disabled; 9 ÷ 27 (V x 10)	oF	
26	U.Ud Voltage alarm delay	oF Function disabled; -01 ÷ -59 (s); 01 ÷ 99 (min)	oF	
27	U.OU Voltage calibration offset	-30 ÷ +30 V	0	

8. MAINTENANCE

8.1 Cleaning

We recommend cleaning of the instrument only with a slightly wet cloth using water and not abrasive cleaners or solvents.

8.2 Disposal



The appliance (or the product) must be disposed of separately in compliance with the local standards in force on waste disposal.

9. WARRANTY AND REPAIRS

The instrument is under warranty against manufacturing flaws or faulty material, that are found within 18 months from delivery date. The warranty is limited to repairs or to the replacement of the instrument.

The eventual opening of the housing, the violation of the instrument or the improper use and installation of the product will bring about the immediate withdrawal of the warranty effects.

In the event of a faulty instrument, either within the period of warranty, or further to its expiry, please contact our sales department to obtain authorisation for sending the instrument to our company.

The faulty product must be shipped to Ascon Tecnologica with a detailed description of the faults found, without any fees or charge for Ascon Tecnologica, except in the event of alternative agreements.

10. TECHNICAL DATA

10.1 Electrical characteristics

Power supply: 115... 230 VAC ±10%;

AC frequency: 50/60 Hz;

Power consumption: 5 VA about (115 V); 10 VA about (230 V);

Inputs: 1 input for NTC temperature probes

(103AT-2, 10 k.Ω @ 25°C);

1 free of voltage digital input ;

Output: 1 relay output SPST-NO:

	EN 61810	EN 60730	UL 60730
Out1 (R) - SPST-NO - 16A - 1HP 250V, 1/2HP 125 VAC	16 (9) A	10 (4) A	12 A Res., 30 LRA, 5 FLA
Out1 (S) - /SPDT - 16A - 1HP 250V, 1/2HP 125 VAC	16 (9) A	10 (4) A	12 A Res., 30 LRA, 5 FLA

Relay output Electrical life: 100000 operations;

Action type: Type 1.B (EN 60730-1);

Overvoltage category: II;

Rated impulse voltage: 2500 V at 115/230 V;

Protection class: Class II;

Isolation: Reinforced insulation between the low voltage parts and front panel; no insulation between power supply, relay output and inputs.

10.2 Mechanical characteristics

Housing: Self-extinguishing plastic, UL 94 V0;

Heat and fire resistance category: D;

Ball Pressure Test as described in EN60730: accessible parts 75°C; support live parts 125°C;

Dimensions: 82 x 38 mm, depth 33.5 mm;

Weight: about 150 g;

Mounting: Incorporated flush in panel with Ø10.5 hole fixed with an M10 nut or with 2 self-threading screws with Ø3.2 mm;

Connections:

Power supply and Outputs: Faston 6.3 mm for 0.2 ÷ 2.5 mm²/AWG 24 ÷ 14 cables;

Inputs: Mini removable connectors with pitch 2.54 mm;

Pollution degree: 2;

Operating temperature: 0 ÷ 50°C;

Operating humidity: < 95 RH% with no condensation;

Storage temperature: -25 ÷ +60°C.

10.3 Functional features

Temperature Control: ON/OFF mode;

Defrost control: Interval cycles by stopping compressor;

Measurement range: NTC: -50 ÷ +109°C/-58 ÷ +228°F;

Software class and structure: Class A;

Compliance:

- Directive 2004/108/CE (EN55022: class B; EN61000-4-2: 8kV air, 4kV cont.; EN61000-4-3: 10V/m; EN61000-4-4: 2kV supply and relay outputs, 1kV inputs; EN61000-4-5: supply 2kV com. mode, 1 kV diff. mode; EN61000-4-6: 3V);
- Directive 2006/95/CE (EN 60730-1, EN 60730-2-9).

11. HOW TO ORDER

MODEL

ET1 - = Electronic controller for cooling units

a: NFC PARAMETER PROGRAMMING

- = Not present

N = Controller programmable through NFC

b: POWER SUPPLY

4 = 115...230 VAC (not isolated with capacitor)

c: OUTPUT 1 (OUT 1)

R = Relay output SPST-NO 16A-AC1 (resistive load)

S = Relay output SPDT 16A-AC1 (resistive load)

d: POWER SUPPLY AND OUTPUT TERMINALS

F = Faston 6.3 mm

e: INPUT TERMINALS

1 = 2 input connectors pitch 2.54 mm with 2 + 3 poles (Standard)

2 = 2 input connectors pitch 2.54 mm, 90°bended with 2 + 3 poles

3 = 2 input connectors pitch 2.54 mm, with clip and 2 + 3 poles

F: HOUSING/KEYS

O = Standard Black with knob and horizontal 0 (zero) reference

V = Standard Black with knob and vertical 0 (zero) reference

- = Standard Black without knob

ET1 - a b c d e f g h ii jj

g, h: RESERVED CODES; ii, jj: SPECIAL CODES