



e34B

DIGITAL ELECTRONIC TEMPERATURE CONTROLLER WITH DEFROSTING FUNCTION



DIFFUSION Service

TOUTE LA RÉGULATION

REGULATION - MESURE - INSTRUMENTATION - AUTOMATISME
www.diffusion-service.fr - 02.51.65.99.99 - info@diffusion-service.fr
Z.A.E du Moulin - 3 rue Marie CURIE - 85130 CHANVERRIE

PREFACE

This manual contains the information necessary for the product to be installed correctly and also instructions for its maintenance and use; we therefore recommend that the utmost attention is paid to the following instructions and to save it.

This document is the exclusive property of Ascon Tecnologic S.r.l. which forbids any reproduction and divulgation, even partially, of the document, unless expressly authorized. Ascon Tecnologic S.r.l. reserves the right to make any formal or functional changes at any moment and without any notice. Ascon Tecnologic S.r.l. and its legal representatives do not assume any responsibility for any damage to people, things or animals deriving from violation, wrong or improper use or in any case not in compliance with the instrument features.

Whenever a failure or a malfunction of the device may cause dangerous situations for persons, thing or animals, please remember that the plant has to be equipped with additional electromechanical devices which will guarantee safety.

Index

1. Instrument description	1
1.1 General description	1
1.2 Front panel description	2
2. Programming	2
2.1 Fast Normal Set Point Programming	2
2.2 Standard mode parameters programming	3
2.3 Parameter protection using a Password	3
2.4 Customized mode parameter programming (parameters programming level).....	3
2.5 Reset parameters to default value	4
2.6 Keyboard lock function	4
2.7 Variables display	4
3. Usage warnings	4
3.1 Admitted use	4
4. Installation warnings	5
4.1 Mechanical mounting	5
4.2 Dimensions [mm].....	5
4.3 Electrical connections.....	5
5. Functions	6
5.1 ON/Stand-by function.....	6
5.2 Normal, Economic and Turbo operation.....	6
5.3 Measure and display configuration	7
5.4 Digital input configuration	7
5.5 Outputs and buzzer configuration.....	7
5.6 Temperature control	8
5.7 Compressor protection function and power-on delay.....	9
5.8 Defrost control.....	9
5.9 Evaporator fans control	12
5.10 Alarm functions	12
5.11 Function of keys \square / \square and \square / \square	13
6. Accessories	14
6.1 Parameters configuration by A01.....	14
6.2 Parameters configuration by AFC1	14
6.3 Remote display "TVR Y"	14
6.4 RS485 Serial Interface with ARS1.....	15
7. Programmable parameters table	16
8. Problems and maintenance	19
8.1 Notifications.....	19
8.2 Cleaning.....	19
8.3 Disposal	19
9. Warranty and Repairs	19
10. Technical data	19
10.1 Electrical characteristics	19
10.2 Mechanical characteristics.....	19
10.3 Functional features.....	20
11. Instrument ordering code	20

1. INSTRUMENT DESCRIPTION

1.1 General description

The model **e34B** is a microprocessor based digital electronic temperature controller that is typically used in cooling applications with **ON/OFF temperature control** and **defrost control** at time intervals, by arrival at temperature or by length of time of continuous compressor operation through stopping the compressor, electric heating or hot gas/cycle inversion.

The controller is equipped with special **defrost optimization functions** and with other functions that can be used to obtain **energy savings from the controlled system**.

The instrument has up to **4 relay** (or 2 relay and 2 SSR) **outputs** and up to **3 NTC temperature probes** inputs **one of which** can be **configured as digital input**.

The instrument has an **internal buzzer** for the **acoustic alarms** signalling and a **voltage alarm system** that deactivates the outputs if the **mains voltage is too high/low**.

The **4 outputs** can be used to **control the compressor** or the **temperature control device**, the **defroster**, the **evaporator fans** and a **configurable auxiliary device** (Light, Alarm, etc.). The **3 inputs for temperature probes** can be used for the **cell temperature control**, to measure the **evaporator temperature** and/or other **auxiliary temperatures** (e.g. products temperature, condenser temperature, etc.).

The **digital input**, alternative to the **Pr3** probe, can be configured to **perform various functions** such as: cell gate signal, defrost commands, selection of a different set of temperature control, signaling of an external alarm, activation of a continuous cycle, activation of the auxiliary output etc..

The operating parameters configuration can be made through the **keypad**, through the **A01** device connected to the TTL port (standard) or using the **NFC** communication (optional).

1.2 Front panel description

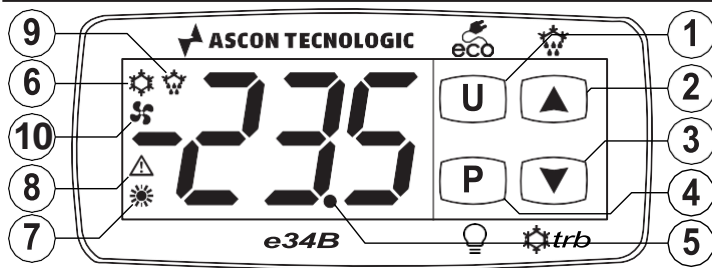

- 1 **U/eco**: Pressed for about 1 s enables the *ECO* function or turns the instrument ON/OFF (Stand-by). The function selection is made with t_{Uf} parameter. Pressed for 5 s together with the **P/Q** key, allows to access to the parameter programming mode. Pressed for 5 s together with the **▼/trb** key allows to access the variable display mode. In programming mode it is used to return to normal operation;
- 2 **▲/trb**: In normal mode, pressed and released allows to access the direct Set Point selection/change modality. Pressed for 5 s can be used to start/stop manual defrost cycle (☼). In programming mode and in variable display mode is used to select the parameters and to increase the value to be set. In programming mode can be used together with **P/Q** key to change parameters level. When the keyboard is locked, the keys **▲/trb** and **P/Q** used together (hold pressed for 5 s), unlock the keyboard.
- 3 **▼/trb turbo**: In normal mode, pressed and released allows to access the direct Set Point selection/change modality. Pressed for 5 s can be used to start/stop a control cycle with "turbo" modality (⚙️). In programming mode and in variable display mode is used to select the parameters and to increase the value to be set.
- 4 **P/Q**: Pressed for about 1 s enables/disables the output selected as "Light". The function selection is made with t_{fb} parameter. Pressed for 5 s together with the **U/eco** key, allows to access to the parameter programming mode. In programming mode is used to enter in parameters edit mode and confirm the entered values. In programming mode **P** can be used together with the **▲/trb** key to change the programming level of the parameters. Pressed together with the **P/Q** key for 5 s allows the keyboard unlock.
- 5 **LED dp/Stand-by**: During the normal operation is the decimal point, when the instrument is placed in Stand-by mode, this is the only lighted LED. In programming mode, while the parameter code is displayed, the dot indicates the parameter protection level: **not protected** (lit up), **protected** (flashing) and **hidden** (turned OFF).

- 6 **LED ☼**: Indicates the output status (compressor or temperature control device) when the instrument is programmed for **cooling operation**; **ON** (lit up), **OFF** (turned OFF) or **inhibited** (flashing).
- 7 **LED ☼**: Indicates the output status (compressor or temperature control device) when the instrument is programmed for **heating operation**; **ON** (lit), **OFF** (turned OFF) or **inhibited** (flashing).
- 8 **LED ▲**: Indicates the **alarm status**: **ON** (lit), **OFF** (turned OFF) or **silenced or stored** (flashing).
- 9 **LED ☼**: Indicates that the **defrost is in progress** (on) or **drainage time in progress** (flashing).
- 10 **LED ⚙️**: Indicates **fan output status ON** (on), **OFF** (off) or **inhibited** (flashing).

2. PROGRAMMING

2.1 Fast Normal Set Point Programming

The instrument allows, through the t_{Ed} parameter, to manage the selection of the regulation Set point according to two distinct modes.

Setting $t_{Ed} = 1$ the instrument allows the **SP1** Set Point setting inside the limits inserted with SPH and SPE parameters. Using this method, press and release the **▲** or **▼** key, the controller answers showing the **SP1** active, at this point, using the **▲** and **▼** keys is possible to change the SP2 value to the desired one. Once the desired value has been selected, press the **P/Q** key or wait 10 s after which the instrument makes the new set Point value active and the display returns to the normal operating mode.

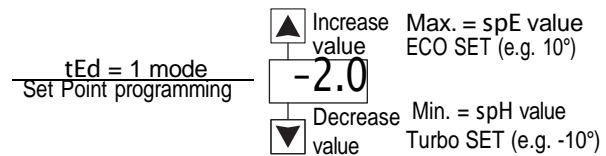

Setting $t_{Ed} = 2$, the controller allows to select which of the 3 pre-set Set Points ($SP1$, $SP2$, $SP3$) is to be set to active. In this mode, pressing and releasing the **ss / dd** key the instrument shows the active Set Point ($SP1$, $SP2$, $SP3$) alternated to its value, pressing the **▲**/**▼** keys again it will be possible to select which one of the three is to be activated. Once the desired Set Point has been activated, press the **P/Q** key or wait 10 s after which the instrument makes the selected Set Point active and the display returns to the normal operating mode.

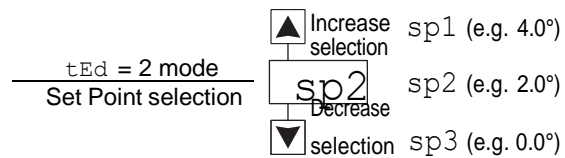

Note: The use of the device with $t_{Ed} = 2$ is the most practical and simple for the end user who, with the operations illustrated below, can easily select, as the active, one among the 4/5 preset Set Point temperatures (SPE , $SP1$, $SP2$, $SP3$ and SPH).

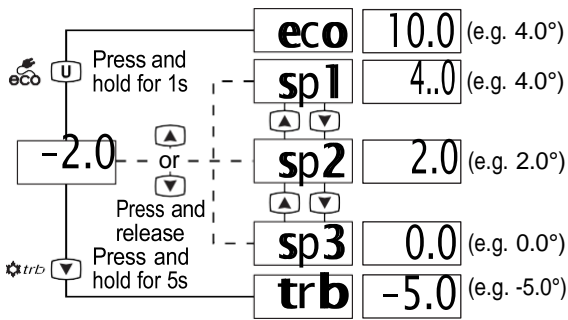

2.2 Standard mode parameters programming

To access the instrument function parameters when password protection is disabled, press the keys P/Q and U/eco at the same time and keep them pressed for about 5 s, after which the display shows the code that identifies the first programmable parameter. Press the \uparrow/P / \downarrow keys to display the desired parameter, then, pressing the P/Q key, the display shows the parameter code alternated to its value that can be changed with the \uparrow and \downarrow keys.

Once the desired value has been set, press P/Q again: the new value is stored and the display shows only the code of the selected parameter. Pressing the \uparrow/P / \downarrow keys, it is now possible to select another parameter and change it as described. To exit the program mode, press no keys for about 30 s or keep the U/eco key pressed for 2 s.

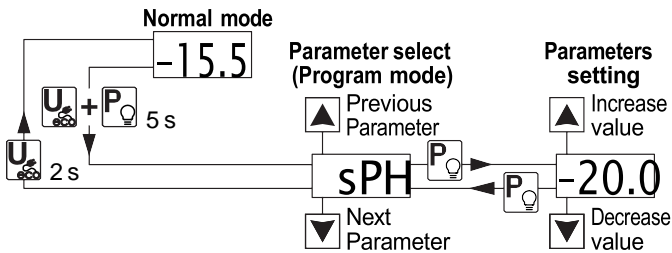

Note: With parameters in which the variable to be set is a time, the least significant time unit (s when s/min, min when min/h) is displayed in negative form (with the sign -); the most significant time unit (m when s/min, h when min/h) is displayed as a positive value (without the sign).

2.3 Parameter protection using a Password

The instrument has a parameter protection function using a password that can be personalised through the t_{pp} parameter. To protect the parameters, set the desired password number in the parameter t_{pp} .

When the protection is active, press the keys P/Q and U/eco at the same time and keep them pressed for about 5 s, after which the display shows $r.p.$. Now press only the P/Q key, the display shows 0; using the \uparrow/P / \downarrow keys, insert the programmed password number and press the key P/Q again. If the password is correct the instrument displays the code of the first parameter and it will be possible to program the instrument in the same way described in the previous section. The password protection can be disabled by setting $t_{pp} = \text{oF}$.

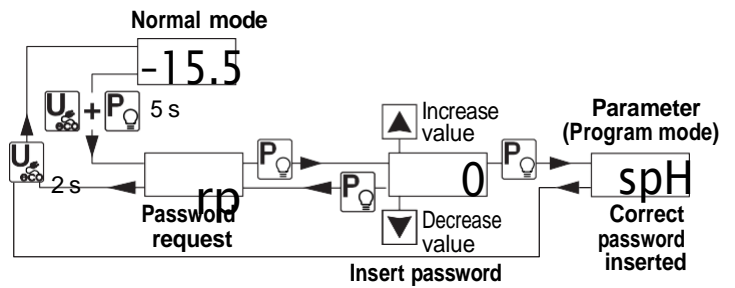

- Notes:**
1. All parameters are configured by default at “protected” level so that setting the t_{pp} parameter protects all parameters with the password.
 2. If the Password gets lost, just switch OFF and ON the instrument, push P/Q key during the initial test keeping it pressed for 5 s. In this way it is possible to access all the parameters, verify and modify the parameter t_{pp} .

2.4 Customized mode parameter programming (parameters programming level)

The password hides all the configuration parameters behind a factory set password to avoid unwanted changes to the controller parameters. To make a parameter accessible without having to enter the password when t_{pp} password protection is activate, use the procedure that follows:

Enter the program mode using the t_{pp} Password and select the parameter that must be accessible (no password protection).

Once a parameter is selected, if the **dp LED flashes** the parameter is programmable by entering the password (is “protected”). If the **dp LED is steady ON** the parameter is programmable without password (is “unprotected”).

To change the parameter visibility, press the P/Q key and keeping it pressed also press the \uparrow button.

The **dp LED** changes its state indicating the new level of parameter accessibility (**ON** = not protected; **flashing** = password protected).

In case some parameters are not protected, accessing the the programming mode the device first shows the not protected parameters, then the $r.p.$ parameter (through which will be possible to access the “protected” parameters).

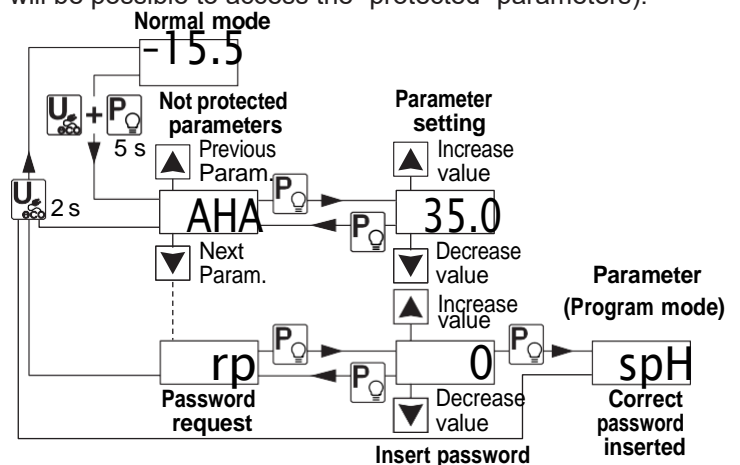

2.5 Reset parameters to default value

The instrument allows the reset of the parameters to values programmed in factory as default

To restore the default parameters value set value -48 at $r.p$ password request. Therefore, to make the reset to the default parameters, enable the Password using the t_{PP} parameter so that the $r.p$ setting is requested, at this point insert **-48** instead of the programmed access password.

Once confirmed the password with the (P/Q) key the display shows “---” for 2 s therefore the instrument resets all the parameters to factory default setting.

2.6 Keyboard lock function

On the instrument it is possible to completely lock the keyboard. This function is useful when the controller is in an accessible area and the changes must be avoided.

To activate the keyboard lock it is enough program the parameter t_{Lo} to a value different from **oF**.

The t_{Lo} value is the keys inactivity time after which the keyboard will be automatically locked.

Therefore, pressing no buttons for the time set at t_{Lo} , the instrument automatically disables the keys normal functions. When the keyboard is locked, if any of the key is pressed, the display shows L_n to indicate that the lock is active.

To unlock the keyboard it is enough to contemporaneously press $(P/Q) + (\uparrow/\downarrow)$ keys and keep them pushed for 5 s, after which the label L_F appears on the display and all the key functions will be available again.

2.7 Variables display

The display normally shows the variable set with parameter ids , but it is possible to display all the measurement and operating variables by simultaneously pressing the (U/turbo) and $(\downarrow/\text{turbo})$ keys for 5 s.

The display will alternately show the code that identifies the first displayable variable and its value.

So with the (\uparrow/\downarrow) keys keys you can view all the variables:

- $pr1$ Probe **Pr1** temperature measurement;
- $pr2$ Probe **Pr3** temperature measurement;
- $pr3$ Probe **Pr3** temperature measurement;
- Lt Minimum stored temperature readed by **Pr1** probe;
- Ht Maximum stored temperature readed by **Pr1** probe;
- U Mains voltage read by the instrument ($ULU/UHU \neq oF$).

Peak values **Lt** and **Ht** are not saved when power failure occurs; a peak can be reset by pressing the (U/turbo) button for 3 s while viewing that peak. After 3 s, the display shows “---” for an instant to indicate that the displayed peak has been erased and assumes the temperature measured at that moment as the new peak. To reset the other peak repeat the procedure while the system is displaying its value.

To exit the variable display mode, press no keys for about 10 s or press the (P/Q) key.

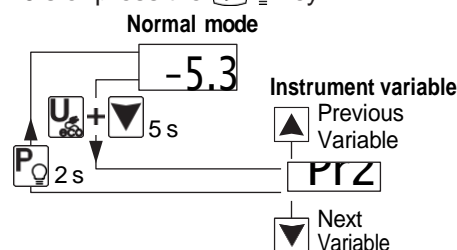

3. USAGE WARNINGS

3.1 Admitted use

The instrument has been projected and manufactured as a measuring and control device to be used according to EN60730-1 at altitudes operation below 2000 m.

Using the instrument for applications not expressly permitted by the above mentioned rule must adopt all the necessary protective measures.

The instrument **MUST NOT BE USED** in dangerous environments (flammable or explosive) without adequate protections. The instrument used with NTC 103AT11 probe (identifiable by the printed code “103AT-11” visible on the sensor part) is compliant with standard EN 13485 (“Thermometers for measuring the air and product temperature for the transport, storage and distribution of chilled, frozen, deep-frozen/quick-frozen food and ice cream”) with the following classification: [EN13485 air, S, A, 2, -50°C +90°C]

Remember that the end user must periodically check and verify the thermometers in compliance with standard EN 13486. The installer must ensure that the EMC rules are respected, also after the instrument installation, if necessary using proper filters.

4. INSTALLATION WARNINGS

4.1 Mechanical mounting

The instrument, in case 78 x 35 mm, is designed for flush-in panel mounting. Make a 71 x 29 mm hole and insert the instrument, fixing it with the provided special brackets.

In order to obtain the declared front protection degree, mount the gasket and use the screw type bracket (both optional).

- Avoid installing the instrument in places with high humidity which can generate condensation or with dirt which can lead to the introduction of conductive substances into the instrument.
- Ensure the adequate ventilation to the instrument and avoid the installation within boxes where are placed devices which may overheat or have, as a consequence, the instrument functioning at temperature higher than allowed and declared.
- Connect the instrument as far as possible from source of electromagnetic disturbances so as motors, power relays, relays, electrovalves, etc..

4.2 Dimensions [mm]

4.2.1 Mechanical dimensions

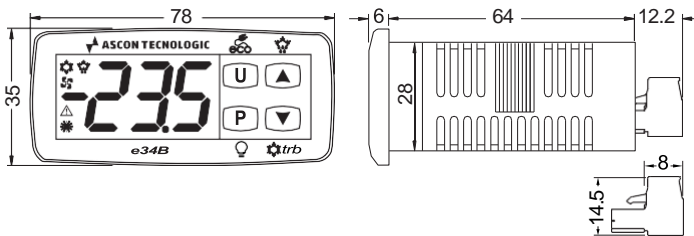

4.2.2 Panel cut-out

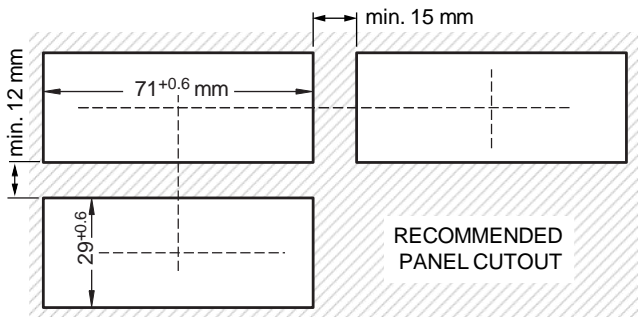

4.2.3 Mounting brackets and gasket

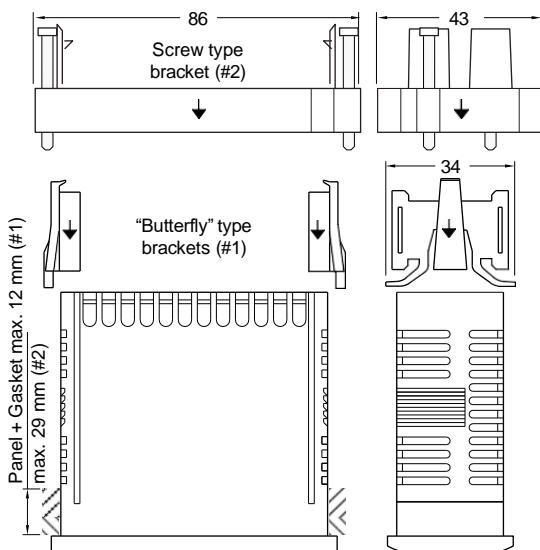

4.3 Electrical connections

Carry out the electrical wiring by connecting only one wire to each terminal, according to the following diagram, checking that the power supply is the same as that indicated on the instrument and that the load current absorption is no higher than the maximum electricity current permitted.

As the instrument is built-in equipment with permanent connection inside housing, it is not equipped with either switches or internal devices to protect against current overloads: the installation will include an overload protection and a two-phase circuit-breaker, placed as near as possible to the instrument and located in a position that can easily be reached by the user and marked as **instrument disconnecting device** which interrupts the power supply to the equipment. Further recommendations:

- The supply of all the electrical circuits connected to the instrument must be properly protected using devices (ex. fuses) proportionate to the circulating currents;
- Use cables with proper insulation, according to the working voltages and temperatures;
- Make sure that the input sensor cables are kept separate from line voltage wiring in order to avoid induction of electromagnetic disturbances;
- If some cables are shielded, the protection shield must be connected to ground **at only one side**;
- When the instrument has a 12 VDC power supply (Order Code **a = F**) it is recommended to use an external TCTR transformer, or with equivalent features (class II insulation) and to use only one transformer for each instrument because there is no insulation between supply and input.

We recommend that a check should be made that the parameters are those desired and that the application functions correctly **before connecting the outputs to the actuators** so as to avoid malfunctioning that may cause irregularities in the plant that could cause damage to people, things or animals.

4.3.1 Electrical wiring diagram

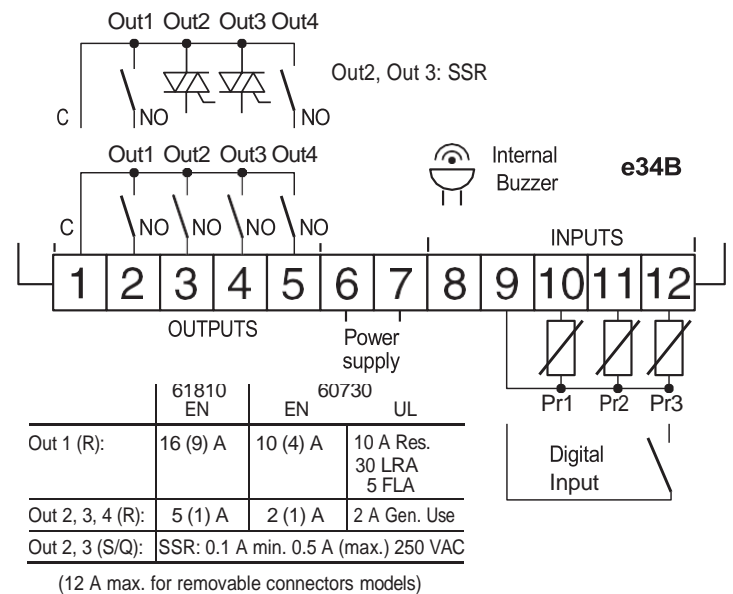

5. FUNCTIONS

5.1 ON/Stand-by function

Once powered the instrument can assume 2 different conditions:

ON: Means that the controller uses the control functions.

STAND-BY:

Means that the controller uses no control function and the display is turned off except for the Stand-by LED.

The transition between Standby and ON is equivalent to power ON the instrument providing the electrical power

In case of power failure, the system always sets itself in the condition it was in before the black-out

The ON/Stand-by function can be selected:

- With the key \square / eco pressed for 1 s if $t_{UF} = 3$;
- Using the Digital Input if parameter $i_{Fi} = 7$;

5.2 Normal, Economic and Turbo operation

The instrument allows to pre-set 5 different control Set points, 3 of which (SP1, SP2, SP3) are **Normal**, one SPE is **Economic** (or Eco) and one SPH **Turbo**.

Associated with each Setpoint there is the relative differential (hysteresis): **Normal** - rd, **Eco** - rEd and **Turbo** - rHe.

As already explained at paragraph "2.1 - Quick setting of the normal Set Point" the "Normal" operating set point can be **only 1** (SP1 if $t_{Ed} = 1$) or selectable between 3 preset values (SP1, SP2, SP3 if $t_{Ed} = 2$).

Note: In the following examples the Set point is generally indicated as **SP**, however the instrument **operates on the basis of the active Set Point**.

5.2.1 Normal/Eco operation selection

This function can be used when you need to switch two functional temperatures (eg. Day/Night or week-day/week-end).

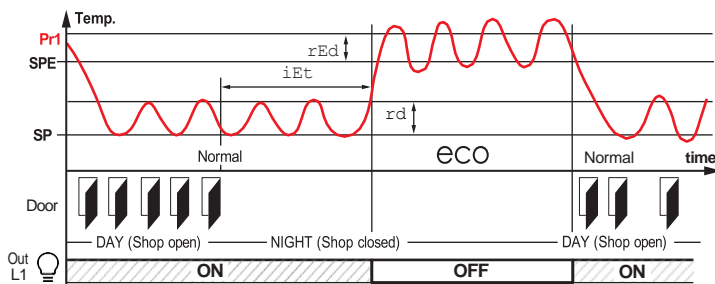

Example of automatic *ECO/Normal* mode activation. during the business hours the door is opened frequently and the controller remains in *Normal* mode. After the i_{Et} time has elapsed since the door has not been opened anymore, the controller switches to *ECO* mode. As soon as the door is opened again, the controller returns to *Normal* mode.

The Normal/Eco operation can be selected in manual mode:

- Using the \square / eco key if parameter $t_{UF} = 2$;
- Using the Digital Input if parameter $i_{Fi} = 6$.

The Normal/Eco operation can be selected in automatic mode:

- Elapsed the i_{Et} time after the door has been closed (Normal/Eco switching).
- At door opening if the SPE Setpoint is activated by i_{Et} parameter (Eco/Normal switching).
- Elapsed the i_{tt} time after the door has been closed and from the activation of SPE Setpoint (Eco mode) by i_{Et} parameter (Eco/Normal switching).

To use this function, it is necessary to set the Digital Input as: $i_{Fi} = 1, 2$ or 3 (door open Input).

If $i_{Et} = \text{oF}$ the selection of Eco/Normal modes via the digital input is disabled.

If $i_{tt} = \text{oF}$ the time-out switching from Eco to Normal mode is disabled.

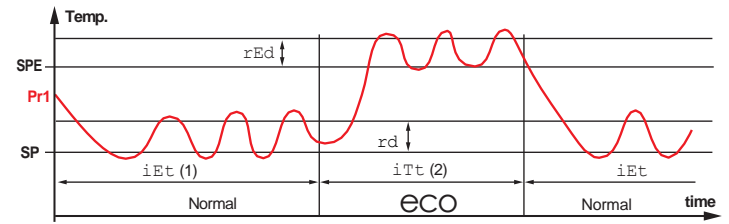

Switching to Economic mode is indicated by the label *Eco*. In addition, the selection of the *Eco* mode is always combined with the function of turning OFF the output configured as **L1** (showcase light).

5.2.2 Turbo/Normal/Eco mode selection

Turbo mode can be used manually when, after a refrigerator load phase, a products temperature decrease is required. It can instead be used automatically to allow the recovery of the products temperature at the end of an *Economic* cycle.

Turbo mode can be selected manually:

- Pressing \square / turbo and maintaining it pressed for 5 s;
- From digital input if parameter $i_{Fi} = 8$;

Turbo mode can be selected automatically:

- Leaving *Eco* mode (only if $r_{HC} = C3$)
- Every time the instrument is switched ON (only if $r_{HC} = C3$ and $Pr1 > SPE + rEd$)

The instrument quits *Turbo* mode automatically at the end of r_{tC} time or manually using the programmed command (key or digital input), the instrument always returns to *Normal* mode.

Setting $r_{HC} = C3$ the operating cycle is:

- At power ON, the instrument starts in the mode it was in when it was switched OFF (*Normal* or *Eco*) unless the temperature at power ON is $> SPE + rEd$. In this case (see the drawing) a *Turbo* cycle is automatically started.
- After time r_{tC} the instrument automatically switches to *Normal* mode.
- If the door is opened frequently, the instrument remains in *Normal* mode. If however the door is not opened for time set at i_{Et} parameter, it automatically switches to *Eco* mode.
- The instrument remains in *Eco* mode until the door is opened again or, if set, until the time-out i_{tt} .
- On leaving *Eco* mode the instrument therefore runs a *Turbo* cycle to allow product temperature to be restored, after which it reverts to *Normal* mode and so on.

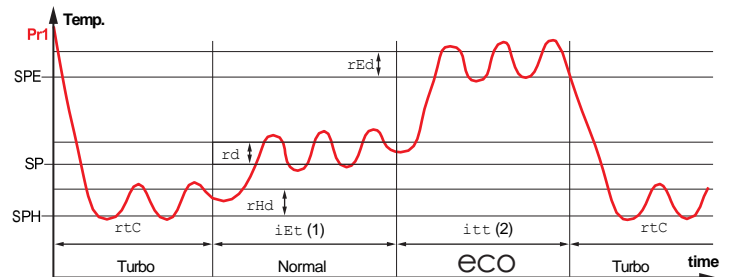

- Notes:**
1. The time i_{Et} is reset every time the door is opened, in the case shown the door is always closed.
 2. The i_{tt} time is stopped as soon as the door is opened, the instrument immediately switches to *Turbo* mode. In the case shown, the door is always closed.

5.3 Measure and display configuration

With parameter i_{uP} it is possible to select the temperature engineering unit and the desired measure resolution (**C0** = °C/1°; **C1** = °C/0.1°; **F0** = °F/1°; **F1** = °F/0.1°).

The instrument allows the measure calibration, which can be used to recalibrate the instrument according to application needs, the calibration is made by using parameters i_{C1} (input Pr1), i_{C2} (Pr2 input) and i_{C3} (Pr3 input).

Parameters i_{P2}/i_{P3} allow to select the controller usage of **Pr2/Pr3** probe measure as:

EP **Evaporator probe**: used to manage the defrost and the evaporator fans (see relative functions).

Au **Auxiliary probe**: can be used as a display-only probe, but it is also possible to associate temperature alarms (possible uses: product probe, anti-freeze probe, etc.);

DG Digital Input only for **Pr3** input.

If probe input is not used, set i_{P2} or $i_{P3} = \text{oF}$.

Two inputs cannot be set to perform the same function.

If two inputs are set to do the same function, this is done only by the **Pr2** input.

Using i_{Ft} parameter is possible to set a software filter to decrease the input sensibility to rapid temperature changes, increasing the sampling time, to stabilize the reading of the measurement inputs.

In addition to this filter there are other two similar filters used only for the **Pr1** probe measure visualization, these regard the increasing (t_{du} parameter) and the decreasing (t_{dd}) of **Pr1** measurement to avoid to display fast temperature variations.

The filter blocks the maximum decrement displayed at 0.1° every t_{dd} seconds and the maximum increase displayed every t_{du} seconds. These filters are reset at power OFF.

Through the i_{dS} parameter is possible to set the variable normally displayed:

P1 **Pr1** probe measurement;

P2 **Pr2** probe measurement;

P3 **Pr3** probe measurement;

SP Active Set Point;

Ec **Pr1** probe measure if the instrument is in *Normal* mode, the label **Eco** if the instrument is in *Eco* mode;

oF If the numerical display must be switched OFF.

When one of the measures is displayed ($i_{dS} = \text{P1/P2/P3/Ec}$) the i_{cU} parameter allows to set an offset that is applied only to the displayed variable (all controls are made according to the correct temperature value, changed only by the calibration parameters).

Regardless of what is set at i_{dS} parameter, all the measurement variables can be shown as described at paragraph: "2.7 - Variables display".

It is also noted that the **Pr1** probe display can also be changed by "Defrost display lock" function via the ddL parameter (see the *Defrost function*).

5.4 Digital input configuration

The digital input function (available on **terminal 12**) is defined using the i_{Fi} parameter and the action is delayed for the time programmed with parameter i_{ti} . The i_{Fi} parameter can be configured for the following functions:

0 Digital input not active;

1 Cell door opening with NO contact: at input closure (and after the i_{ti}) the instrument displays alternately **oP** and the variable set at i_{dS} parameter. With this mode of operation of the digital input activates also the time set with parameter A_{oA} elapsed which the alarm is activated to warn that the door has been left open. In addition, at door opening, the instrument returns to *Normal* operation if it was in *Eco* mode and the *Eco* mode activation was enabled through parameter i_{Et} ;

2 Cell door opening with NO contact: Similar to $i_{Fi} = 1$ but with evaporator fans stop. In addition, at open door alarm intervention (A_{oA}), the fans are restarted;

3 Cell door opening with compressor and fan outputs lock and NO contact: similar to $i_{Fi} = 2$ but with compressor and fans lock. At open door alarm intervention (A_{oA}) both the fans and the compressor are re-activated.

4 External alarm signal with NO contact: at input closing (and after the i_{ti} time) the alarm is activated and the instrument alternately shows on the display: **AL** and the variable set with parameter i_{dS} ;

5 External alarm signal with all control outputs disabled and NO contact: at input closing (and after the i_{ti} time) all the control outputs are disabled, the alarm is activated and the instrument alternately shows on the display: **AL** and the variable set with parameter i_{dS} ;

6 *Normal/Eco* mode selection with NO contact: at input closing (and after the i_{ti} time) the instrument switches to *Eco* operation mode. Opening the digital input, the instrument returns in *Normal* operation mode.

7 Instrument On/Off (stand-by) selection with NO contact: at input closing (and after the i_{ti} time) the instrument is switched ON while it is placed in Stand-by mode when the digital input is open;

8 *Turbo* cycle activation command with NO contact: at input closing (and after the i_{ti} time) the instrument starts a Turbo cycle;

-1 ÷ -8 - Features identical to the above but obtained through a NC contact and a reversed logic operation.

5.5 Outputs and buzzer configuration

The instrument outputs can be configured by the relative parameters o_{o1} , o_{o2} , o_{o3} and o_{o4} . The outputs can be configured for the following functions:

ot To control the temperature control device (e.g. Compressor). To manage the cooling control device for neutral zone control or Cooling ($r_{HC} = \text{nr}$);

df/DH/-d Defroster control;

Fn To control the evaporator fans;

Au To control the auxiliary device;

At To control a silenceable alarm device through a contact that is NO in normal operation then closed during the alarm;

AL To control an alarm that cannot be silenced through a contact that is NO in normal operation then closed during the alarm;

An To control an alarm with a memory function through

- a contact that is NO in normal operation then closed during the alarm (see alarm memory);
- t To control a silenceable alarm device through a contact that is NC in normal operation then opened during the alarm;
- L Control an alarm that cannot be silenced through a contact that is NC in normal operation then opened during the alarm;
- n To control an alarm with a memory function through a contact that is NC in normal operation then opened during the alarm;
- on To command a device that must be turned ON when the instrument is ON. The output is therefore deactivated when the instrument is not powered or is in standby mode. This mode of operation can be used as a control of the shop window lighting, anti-fogging resistors or other utilities;
- HE To control a heating device in neutral zone ($r_{HC} = nr$);
- L1 Showcase light connected to *Normal/Eco* mode. The output turns ON when the *Normal* mode is active while it is turned OFF when the *Eco* mode is active;
- L2 Internal cell light. The output is always OFF and only switches ON from a digital input signal when it is configured as door opening switch ($iFi = 1, 2, 3$);
- dH Pre and post defrost heater output;
- d Defrost control with inverted logic (inverted dF);
- oF Output disabled.

If one of the outputs is configured as auxiliary output (= Au), its function is set by parameter oFo and its operation can be conditioned by the time set at parameter otu .

oFo parameter can be configured for the following functions:

- oF Auxiliary output not active;
- 1 Temperature control output delayed with NO contact: the auxiliary output is activated with a delay that can be set with parameter otu applied to the output configured as **ot**. The output is then turned OFF at the same time as the **ot** output is disabled. This function mode can be used as a command for a second compressor or for all other working utilities according to the same **ot** output conditions, but which must be delayed after the start up of the compressor to avoid excess electricity absorption;
- 2 Activation by digital input. The output is activated by a digital input signal if correctly configured ($iFi = 9$). These commands have a bi-stable (toggle) function (at first pression the output is activated, at the second is disabled). The **Aux** output can be turned OFF automatically after the time set at parameter otu .

When $otu = oF$ the output is activated and deactivated only manually, via the digital input. Differently, the output, once activated, is turned OFF automatically after the otu time. This mode of operation can be used as a control of the shop window lighting, anti-fogging resistors or other utilities.

If present, the internal buzzer can be configured by parameter obu for the following functions:

- oF Buzzer always disabled;
- 1 The Buzzer sounds when an alarm is active;
- 2 The Buzzer sounds when a key pressed (no alarm);
- 3, 4 The Buzzer sounds both when a key pressed and when an alarm is active.

5.6 Temperature control

The instrument controls the temperature with an **ON/OFF** action and operates on the outputs configured as **ot** and **HE** depending on the **PR1** probe measuring, the active Set Point/s **SP1** (or **SP2, SP3, SPE** and **SPH**), the Hysteresis rd (or rEd and/or rHd) and the function mode set with r_{HC} . Using r_{HC} can be set the following functioning modes:

C/C- Cooling

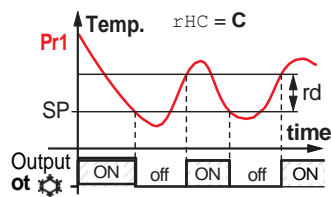

H/H- Heating

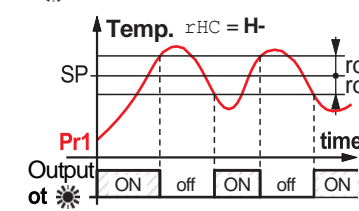
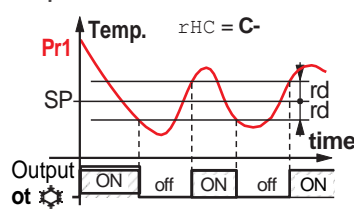
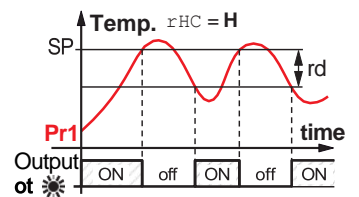

Depending on the function mode programmed with parameter r_{HC} the differential (Hysteresis) is automatically considered by the controller with positive values for **Cooling** controls ($r_{HC} = C$) or negative values for **Heating** controls ($r_{HC} = H$) or **Control with Symmetrical Hysteresis** with positive and negative values around the Set Point for Cooling ($r_{HC} = C-$) and Heating ($r_{HC} = H-$) controls.

nr Neutral Zone

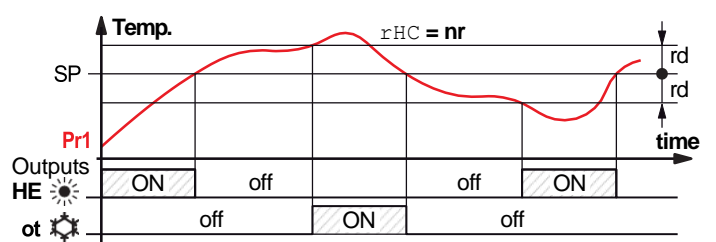

When $r_{HC} = nr$, the output configured as **ot** operates with a cooling action (like $r_{HC} = C$) while the output configured as **HE** operates with a heating action both with the Active Set Point (**SP1, SP2, SP3, SPE** or **SPH**). The intervention differential ($rd/rEd/rHd$) is automatically assumed by the controller to have positive values for the cooling action and negative values for the heating action.

HC Cooling and Heating with independent Set Points

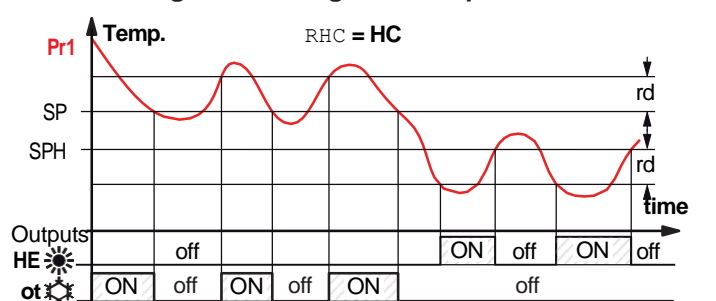

As in the previous case, when $r_{HC} = HC$ the output configured as **ot** operates with cooling action (like $r_{HC} = C$) while the output configured as **HE** operates with heating action ($r_{HC} = H$). In this case, however, the Set Point for the **ot** output is the active one between **SP, SPE** or **SPH**, while for the **HE** output the Set Point is **SPH**. The intervention differential for the **ot** output is the active between rd, rEd or rHd and is automatically assumed by the controller to have positive values for the

cooling action while for the output **HE** the differential is R_{Hd} considered with negative values as for the Heating actions. In this mode, the activation of the *Turbo* cycle causes the instrument to operate with Neutral Zone and SPH set point.

C3 Cooling with three automatic modes

The instrument operates in cooling mode only, but this selection activates automatic switching between the three *Normal/Eco/Turbo* modes (described at paragraph “Operating modes”).

The time protections described in the next paragraph ($PP1/PP2/PP3$) always work on the **ot** configured output. In the event of a probe error, it is possible to set the instrument so that the **ot** output continues working in cycles according to the times programmed with parameter $rt1$ (activation time) and $rt2$ (deactivation time). If a **Pr1** probe error occurs, the instrument activates the **ot** output for $rt1$ time, then disables it for $rt2$ time and so on until the error persists.

By programming $rt1 = oF$ the output, in probe error condition, will always be OFF. On the contrary, programming $rt1$ to any value and $rt2 = oF$ the output, in probe error conditions, will always be ON.

Remember that the operation of the temperature controller can be conditioned by the following functions: *Compressor protection function and power-on delay, Defrost, Open door and External alarm with output block* from digital input.

5.7 Compressor protection function and power-on delay

The “Compressor Protection” function aims to avoid repeated compressor start-ups controlled by the instrument in cooling applications or otherwise can be used to add a timed control on the actuator control output.

This function foresees 3 time controls on the switching ON of the output configured as **ot**. The protection consists of preventing the **ot** output being switched ON during the times set with parameters $PP1$, $PP2$ and $PP3$ and therefore that any activation occurs only after all times are elapsed.

1 First control (parameter $PP1$) foresees a delay to **ot** output activation (switching-ON delay).

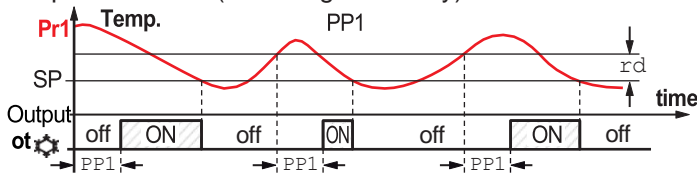

2 Second control (parameter $PP2$) foresees an inhibition to the activation of the output by a time delay that starts when the output is turning OFF (delay after switching-OFF).

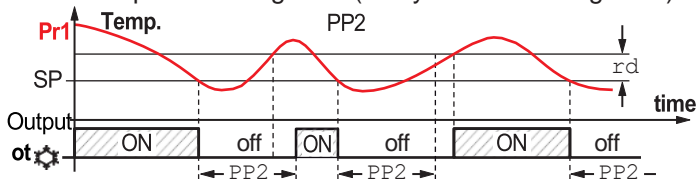

3 Third control (parameter $PP3$) foresees an inhibition to the activation of the output by a time delay that starts

when the output was turned ON last time (delay between two switching-ON).

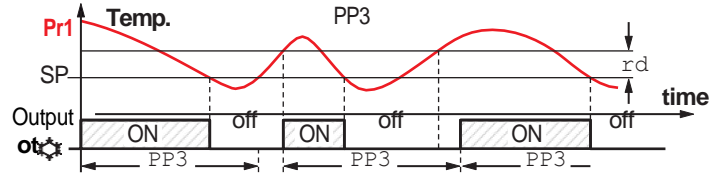

During output inhibition the LED **OUT** (Cool or Heat) blinks. It is also possible to prevent all outputs activation after the instrument is turned ON, for the time set in the parameter Pod . During the power ON delay phase, the display shows the indication od alternated with the normal visualization. All these functions are disabled if the relative parameters are set to **OFF** (oF).

5.8 Defrost control

The defrost control acts on the outputs configured as **ot**, **dF**, **dH** and **-d**. The type of defrost is set by the parameter ddt :

- EL With electrical heating (or By stopping compressor):** while defrosting, the output **ot** is deactivated while the output **dF** is enabled. The defrost will be by Stopping compressor if not using the **dF** output;
 - in With hot gas or Cycle inversion:** while defrosting both the **ot** and **dF** outputs are enabled;
 - no Without compressor output conditioning:** while defrosting, the output **ot** continuous to operate in order to control the temperature, also the output **dF** is enabled;
 - Et With electrical heating and defrosting temperature control:** during defrosting, the output **ot** is deactivated while the output **dF** operate as evaporator temperature control. In this mode the defrost length is by time-out (time ddE). During the defrost, the **dF** output behaves as an heating mode control with Set Point = dtE , differential fixed at $1^\circ C$ and operates with the values of the **EP** evaporator probe. In this functioning mode, if the evaporator probe is not enabled or is in error, the defrost behaves as with selection **EL** (therefore the output **dF** during defrost must always be active).
- The output configured as **dH** can be used to control an additional defrosting resistance activated before defrost for the time set at parameter ddP and can be deactivated after defrost with a delay that can be set with parameter dPd .

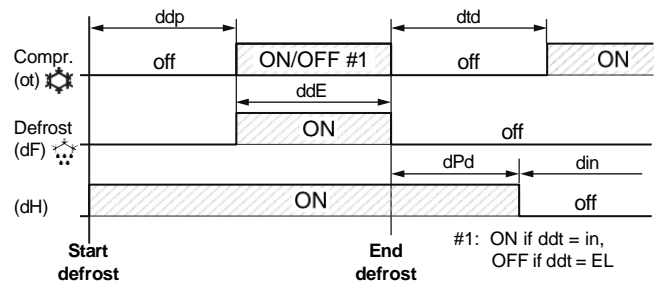

5.8.1 Starting automatic defrosts

The automatic control of defrost occurs:

- By interval times (regular or dynamic);
- By Evaporator temperature;
- By continuous compressor running time.

In order to avoid unnecessary defrosting when the evaporator temperature is high the dtS parameter allows to set the temperature related to the evaporator probe (probe configured as **EP**) under which defrosts are possible.

Therefore, in the modes indicated, if the temperature measured by the evaporator probe is higher than the temperature set with dtS parameter, defrosts are inhibited.

Defrost by regular interval time

As an alternative to programmable defrosts, the instrument allows to execute the defrosts at programmed interval time. Through the ddC parameter, can be set the defrost interval counting mode:

- rt** At real-time power-ON intervals. The ddi interval is counted as the total ignition time of the instrument. This mode is the one currently used in the refrigeration systems.
- ct** At time intervals of the compressor operation. The ddi interval is counted as the sum of the operating times of the **ot** output (**ot** output activated). This mode is usually used in refrigeration systems with compressor stop defrosting.
- cs** Defrost cycle at each compressor stop. The instrument starts a defrost cycle every time the **ot** output is deactivated, when the Set Point is reached or at the expiration of the interval set with ddi parameter. If $ddi = oF$ the defrost happens only at compressor stop. This mode is used only on particular refrigerating machines in which is required the maximum evaporator efficiency at each compressor cycle.

To enable automatic defrost at intervals, after setting the ddC parameter as desired between **rt**, **ct** or **cs**, with the ddi parameter select the time interval between the end of a defrost and the beginning of the next.

The time that the instrument must wait to perform the first defrost after power ON can be set with parameter dSd . This allows to perform the first defrost to a different interval from ddi time.

To force the instrument to perform a defrost cycle at each power ON (as long as the conditions set with parameters dtS and dtE are satisfied) set parameter $dSd = oF$.

This allows the evaporator to be permanently defrosted, even when frequent interruptions to power supply occur that may cause the cancellation of the various defrosting cycles. If instead it is desired that all the defrosts are performed at the same interval time, set $dSd = ddi$.

Setting $ddi = oF$ the Automatic defrost function by interval is totally disabled (including the first, regardless of the time set to the dSd parameter).

Dynamic Defrost Intervals System

Note: For this function is necessary to use the evaporator probe.

To enable the *Dynamic Defrost Intervals System*, program $ddC = rt, ct$ or cs and set $ddd = any\ value$.

Setting $ddd = 0$, the defrost intervals are those set by the user and the *Dynamic Defrost Intervals System* is disabled.

This mode allows to dynamically reduce the defrost interval counting (ddi or dSd if is the first defrost), anticipating, when necessary, the defrost execution, all based on an algorithm that detects a drop in the refrigerator thermal exchange performance.

The algorithm estimates a reduction in thermal exchange based on the increase in temperature difference between **Pr1** (cell control) and evaporator probe (probe configured as **EP**). The result is stored by the instrument when the temperature is close to the Set Point setting.

The advantage of the *Dynamic Defrost Interval* is the possibility to program a defrost interval time longer than normal, so, when necessary, the instrument has the possibility to anticipate the defrost.

If the system results correctly set, it is possible to avoid many unnecessary defrosting cycles (and therefore to obtain a consistent energy saving) that may occur with normal operation when, to ensure more system efficiency, the defrosting interval is programmed with a time that is often too short. With the parameter $ddd - Defrost\ interval\ percentage\ reduction$ is possible to establish the percentage of reduction of the remaining time to start defrost when the conditions for the reduction happen.

Setting $ddd = 100\%$ at the first increase of the stored temperature difference ($> 1^\circ$) between cell (**Pr1**) and evaporator (**EP**) probes a defrost starts immediately.

For correct functioning the instrument needs a first reference value of the temperature difference between cell and evaporator, in this way all variations to the Active Set Point value, to the differential rd , the start of a continuous cycle or a defrost execution deletes this reference value and any reduction cannot be performed until the acquisition of a new reference value.

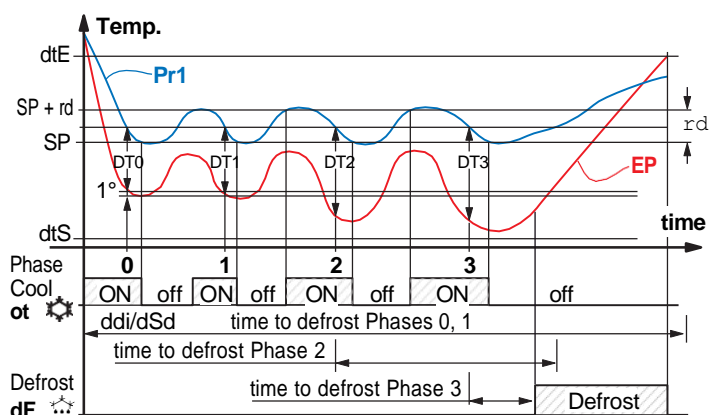

Example “dynamic defrost intervals system” with a reduction $ddd = 40\%$ and end defrost by temperature.

Defrost by evaporator temperature

The instrument starts a defrost cycle when the evaporator temperature (**EP** probe) goes below the dt_E programmed temperature for dSt programmed time.

This modality can be used to guarantee a defrost if the evaporator reaches very low temperatures that normally result symptomatic of a bad thermal exchange in comparison to the normal working conditions.

When $dt_E = -99.9$ the function is disabled.

Defrost by continuous compressor running time

The instrument start a defrost cycle when the compressor is turned ON continuously for the time dcd .

This function is used because the continuous operation for an extended period of the compressor is usually symptomatic of a bad thermal exchange in comparison to the normal working conditions.

When $dcd = oF$ the function is disabled.

5.8.2 Manual defrost

To start a manual defrost cycle, press the key \square/\star when in Normal operation mode and keep it pressed for about 5 s after which, if the conditions are correct, the LED \star lights up and the instrument performs a defrost cycle.

To stop a defrost cycle, press the key \square/\star during the defrost and keep it pressed for about 5 seconds.

5.8.3 End of defrosts

The defrost cycle duration can be time based, or, using the evaporator probe (configured as **EP**) when a specific temperature is reached.

If the evaporator probe is not used, the cycle time is set by parameter ddE (setting $ddE = oF$ the Time-interval or Manual defrosts are disabled).

If, on the other hand, the evaporator probe is used, the end of defrosting occurs when the temperature measured by this probe configured as **EP** exceeds the temperature set with parameter dt_E . If dt_E temperature is not reached within the time set at parameter ddE , the defrost is anyway interrupted. To avoid unnecessary defrosting when the evaporator temperature is high, parameter DtS allows to set the temperature related to the **EP** probe under which defrosts are possible. Therefore, in the indicated modes, if the temperature measured by the **EP** probe is higher than the one set at parameter dts and also dt_E defrosts are inhibited.

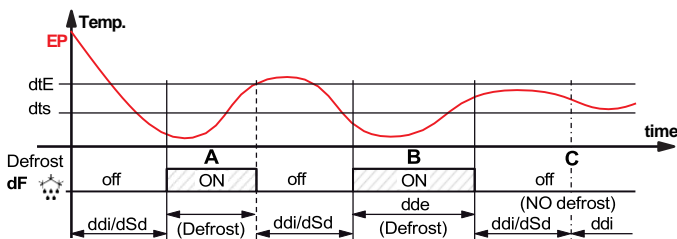

Example: Defrost A ends due to reaching of temperature dt_E , defrost B ends at the end of the ddE time as the temperature dt_E is not reached, defrosting C does not take place as the temperature is higher than dts .

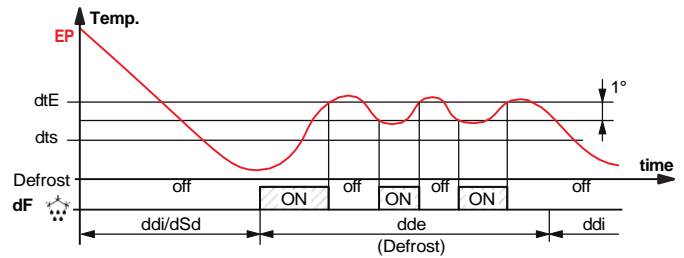

Example of electric defrost with evaporator temperature control: the defrost end after ddE programmed time. During defrost the dF output switch ON/OFF to control evaporator temperature in heating mode with set point dt_E and 1° differential (Hysteresis).

The active defrost is shown on the instrument display with the lighting up of the LED \star .

At the end of defrosting, it is possible to delay the new compressor start up (output **ot**) at the time set in parameter dtd to allow the evaporator to drain. During this delay, the LED \star flashes to indicate the draining state.

5.8.4 Intervals and defrosts duration in case of evaporator probe error

In event of evaporator probe error the defrosts occur at intervals dEi and duration dEE .

In case an error occurs when the time remaining to the start or the end of defrost is lower than the one normally set with the parameters related to error probe conditions, the start or the end takes place with the shortest time.

These functions are provided because when the **EP** evaporator probe is used, the set defrost endurance time is usually longer than necessary (the time ddE is a security time-out) and in case is used the "Dynamic Intervals Defrost System" the interval is usually set more longer than what is normally programmed into instruments that do not have the function.

5.8.5 Display lock during Defrost

Through parameters ddL and AdA it is possible to define the display behaviour during defrost:

- on** The ddL parameter locks the display at the last **Pr1** temperature reading during all the defrost cycle until, at the end of defrost, the temperature has not reached the lock value or the value $[SP + rd]$ or is elapsed the time set at parameter AdA ;
- oF** The display continues showing the temperature measured by the **Pr1** probe during the defrost cycle.

5.9 Evaporator fans control

The control of the evaporator fans on the output configured as **Fn** depends on some specific control statuses of the instrument and the temperature measured by the evaporator probe (**EP**). In the case that the evaporator probe is not used or in error, the **Fn** output is activated only depending on parameters F_{tn} , F_{tF} and F_{FE} .

Parameters F_{tn} and F_{tF} can be used to determine the behavior of the evaporator fans when the **ot** output (compressor) is **OFF**. When **ot** output is **OFF**, it is possible to set the instrument so that the **Fn** output continues working in cycles according to the times programmed at parameters F_{tn} (fan activation time) and F_{tF} (fan deactivation time).

When output **ot** is switched **OFF** the instrument activates the output **Fn** for the time F_{tn} , then deactivates it for the time F_{tF} and so on whilst the output **ot** remains **OFF**.

Programming $F_{tn} = \text{oF}$ the output **Fn** in **ot OFF** condition remains switched **OFF**.

Programming instead F_{tn} to any value and $F_{tF} = \text{oF}$ the output **Fn** when **ot** in **OFF** condition remains switched **ON**. The parameter F_{FE} decides whether the fans must always be switched **ON** independently of the defrosting status ($F_{FE} = \text{on}$) or switched **OFF** during defrosting ($F_{FE} = \text{oF}$). In this later case, it is possible to delay the start up of the fans even after the end of the defrost by the time set at F_{Fd} parameter. When this delay is active the LED  flashes to point out that the F_{Fd} delay is in progress.

When the evaporator probe is used the fans, as well as being conditioned by the parameters F_{tn} , F_{tF} and F_{FE} , are also conditioned by a temperature control.

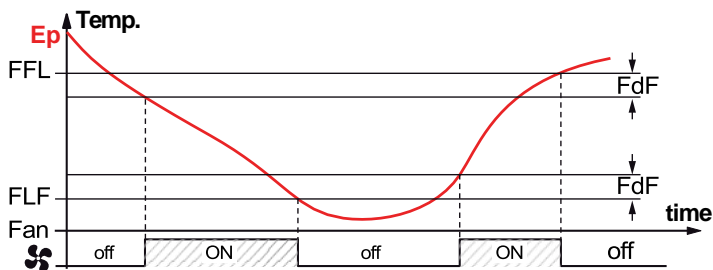



Note: Special attention must be paid to the correct use of the temperature-dependent fan control functions, as in a typical refrigeration application, stopping the evaporator fans blocks heat exchange.

Remember that the fans functioning can be conditioned by the *Door open* function by the digital input.

5.10 Alarm functions

The alarm conditions of the instrument are:

- Probe errors $E1$, $-E1$, $E2$, $-E2$ and $E3$, $-E3$;
- Temperature alarms H_i and L_o ;
- External alarm AL ;
- Door open oP ;
- Power supply alarms H_U , L_U .

The alarm functions acts on LED , on the internal buzzer, if present and configured by the o_{bu} parameter and on the desired output if configured by parameters o_{o1} , o_{o2} , o_{o3} or o_{o4} . Any active alarm condition is signaled lighting up the LED , while the acknowledged alarm status is shown by flashing the LED .

The buzzer (if present) can be configured to point out the alarms by programming parameter $o_{bu} = 1$ or 3 and always acts to signal an acknowledgeable alarm. This means that, when activated, it can be switched **OFF** by briefly pressing any key. Also outputs can operate to signal alarms as specified by the output configuration parameters settings that follow. The possible selections of output parameters for the alarm signalling function are:

- At** When the output is to be activated in alarm condition and can be deactivated manually by pressing any key of the instrument (typical application for an acoustic signal);
- AL** When the output is to be activated in alarm condition but cannot be deactivated manually; it is then deactivated only when the alarm status ceases (typical application for a light signal);
- An** When the output is to be activated in alarm condition and that remains active even when the alarm status has ceased (stored alarm). The disabling action (recognition of a stored alarm) can only be carried out manually by pressing any key only when the alarm status has been removed.
- t** Functions as the function described with **At** but with inverse working logic (the output activated in normal condition and disabled in alarm status).
- L** This alarm function is similar to **AL** but with inverse working logic (output active in normal conditions and disabled in alarm status).
- n** This alarm function is similar to **An** but with inverse working logic (output active in normal conditions and disabled in alarm status).

The instrument offers the possibility to have the alarm memory function activated via the parameter A_{tA} :

- oF** The instrument cancels the alarm signal when the alarm status ends;
- on** The instrument maintains the flashing of  LED also when the alarm status ends. To cancel the alarm memory signal, press any key.

It must be remembered that if an output function is desired with an alarm memory ($o_{o1}/o_{o2}/o_{o3}/o_{o4} = \text{An/-n}$) it is necessary to set the parameter $A_{tA} = \text{on}$.

5.10.1 Temperature alarms

The temperature alarm works according to **Pr1** or **AU** probes measurement, the type of alarm set in the parameter **AAy** the alarm thresholds set in parameters **AHA** (maximum alarm) and **ALA** (minimum alarm) and the relative differential **AAd**.

Through parameter **AAy** it is possible to set the alarm thresholds **AHA** and **ALA** as absolute or relative to the active Set Point, must be related to **Pr1** or **Au** probes and if the message **Hi** (High alarm) and **Lo** (Low Alarm) are to be displayed (or not) at alarm intervention.

Depending on the desired alarm operating mode, parameter **AAy** can be set as:

- 1 Absolute alarms referred to probe **Pr1**, displays **Hi/Lo**;
- 2 Relative Alarms referred to probe **Pr1**, displays **Hi/Lo**;
- 3 Absolute alarms referred to probe **Au**, displays **Hi/Lo**;
- 4 Relative Alarms referred to probe **Au**, displays **Hi/Lo**;
- 5 Absolute alarm referred to probe **Pr1**, displays no labels;
- 6 Relative alarm referred to probe **Pr1**, displays no labels;
- 7 Absolute alarm referred to probe **Au**, displays no labels;
- 8 Relative alarm referred to probe **Au**, displays no labels.

Using some parameters it is also possible to delay the enabling and the intervention of these alarms.

These parameters are:

APA Temperature alarm exclusion time on switching ON the instrument if the instrument is in alarm status when it is switched ON. If the instrument is not in alarm status when it is switched on the time **APA** it is not considered.

AdA Temperature alarm exclusion time at the end of defrost cycle (and, if programmed, after the draining) or after a continuous cycle.

AAt Temperature alarms delay activation time. Temperature alarms are enabled at the end of the exclusion times and are activated after the **AAt** time when the temperature measured by the probe exceeds or goes below the respective maximum and minimum alarm thresholds. The alarm thresholds are those set at parameters **AHA** and **ALA** when the alarms are set as absolute (**AAy** = 1, 3, 5, 7).

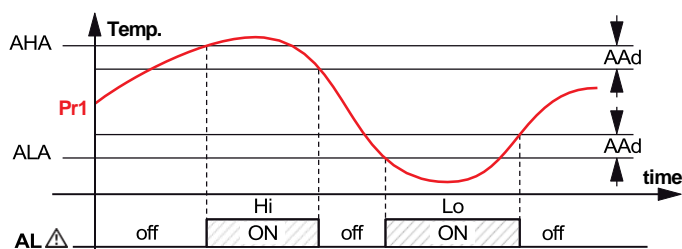

or they assume the values $[SP + AHA]$ and $[SP + ALA]$ if the alarms are relative (**AAy** = 2, 4, 6, 8).

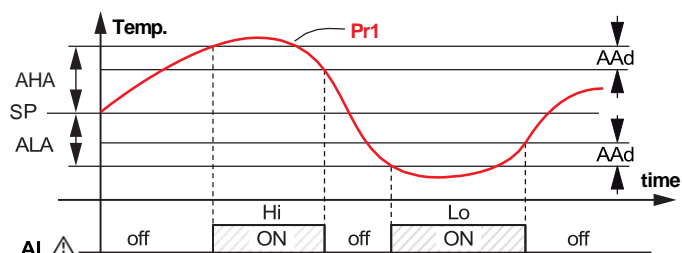

The maximum and minimum temperature alarms can be disabled by setting the related parameters **AHA** and **ALA** = **oF**.

The temperature alarms are signalled lighting up the alarm LED (Δ) and, if configured, also with the buzzer.

5.10.2 External alarm from digital input

The instrument can signal an alarm external to the instrument using the digital input setting **iFi** = 4 or 5. The instrument signals the alarm turning **ON** the alarm LED (Δ) and displaying **AL** label alternated to the variable set with parameter **Ids**. Mode **iFi** = 4 operates no action on the control output, while **iFi** = 5 deactivates the control output at digital input intervention.

5.10.3 Open door alarm

The instrument can signal the open door alarm condition using the digital input setting **iFi** = 1, 2 and 3. As the digital input is activated, the instrument signals that the door is open showing on the display the **oP** label alternated to the variable set with parameter **ids**.

After the delay set with parameter **AoA** the instrument signals the Open Door alarm with the configured devices (buzzer and/or Output), lighting up the LED Δ while showing the **oP** label. At the open door alarm intervention are also re-activated the inhibited outputs (compressor).

5.10.4 Mains voltage alarms

The instrument can automatically disable the control outputs when the mains voltage, measured by the instrument through its power supply, is lower or higher than the values set at parameters:

ULU Low voltage alarm (expressed as V x 10);

UHU High voltage alarm (expressed as V x 10).

When the alarm triggers and after the delay programmed to the **UUD** parameter, the instrument disables the control outputs, signals the alarm by activating the configured device (output and/or buzzer) and shows **HU** (high voltage alarm), or **LU** (low voltage alarm) on the display alternated to the variable set with **ds** parameter.

If the voltage measurement is not correct, it can be changed with an offset that can be set using the **UOU** parameter.

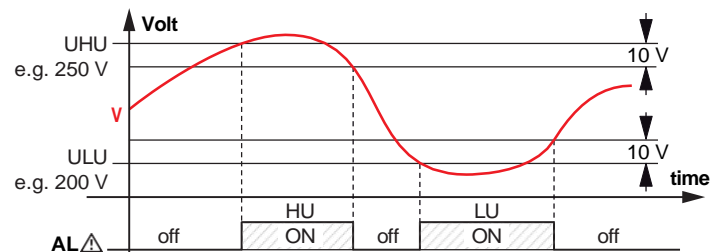

5.11 Function of keys U/eco and L/P

The U/eco key function can be defined using the **tUF** parameter to perform the following functions:

oF The key carries out no function;

- 1 Pressing the key for at least 1 s, is possible to enable/disable the **ECO** operating mode. Once the selection has been made, the display shows for about 1 s the active Set Point code (**SP1**, **SP2**, **SP3** or **Eco**) and its value. When the instrument exits the **ECO** operating mode, it returns at the same operating mode it was using at **ECO** enabling;
- 2 Pressing the key for at least 1 s is possible to switch the instrument from **ON** to **Stand-by** state and vice-versa.

The L/P key function can be defined using the **tFb** parameter to perform the following functions:

oF The key carries out no function;

- 1 Pressing the key for at least 1 s, is possible to enable/disable the **L1** light output or the auxiliary output, if configured as **oFo** = 2.

6. ACCESSORIES

The instrument is equipped with a **TTL** serial communications port with a 5 poles connector that allows to connect some accessories described in the following paragraphs.

6.1 Parameters configuration by A01

Through the **TTL** port and with the **A01** device, is possible to transfer from and toward the instrument all the functioning parameters.



The **A01** is mainly usable for the serial programming of some instruments which need to have the same parameters configuration or to keep a copy of the parameters settings of an instrument and allow its rapid retransmission.

The same device allows to connect a PC via USB with which, through the appropriate configuration software for *AT Universal Config* tools, the operating parameters can be configured. To use the device **A01** it is necessary that the device or instrument are being supplied directly or through the key.

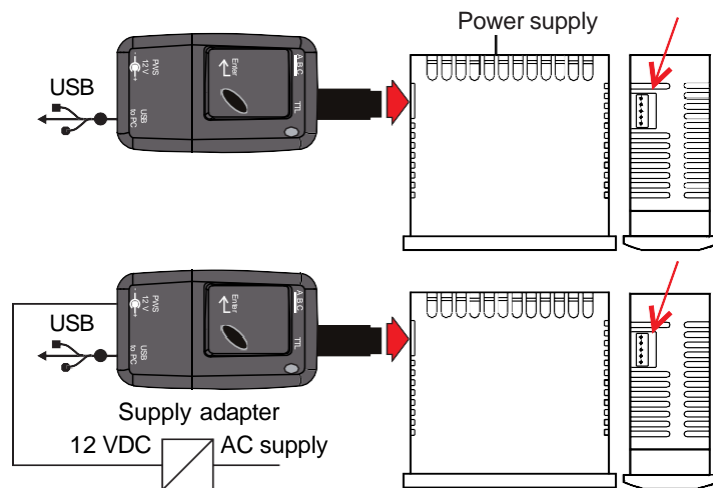

For additional info, please have a look at the **A01** instruction manual.

6.2 Parameters configuration by AFC1

The **AFC1** is a contactless **NFC** (Near Field Communications) connection device that allows to **Upload/Download** the operating parameters **From/To** the instruments.

The **AFC1** is powered directly by the **USB** port through which is connected to a **PC**.



When an instrument is equipped with the **NFC** communication option its operating parameters can be set through a common Personal Computer and the "*AT UniversalConf*" program. Once the changes have been made, the parameters can be sent to the instrument using the **AFC1** device.

To load the operating parameters in the instrument using the **AFC1** device, place the instrument on the **AFC1** with the display facing the **NFC** symbol (☺), then send the parameters to the instrument's memory.

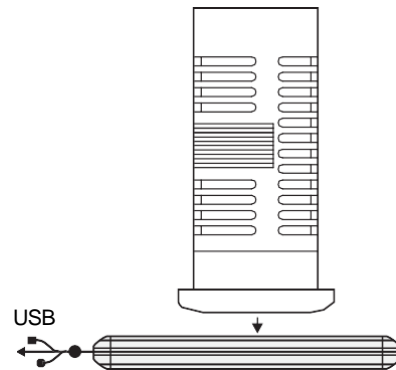

6.3 Remote display "TVR Y"

The **TVR Y** remote display device can be connected to the instrument via the appropriate cable, which can have a maximum length of 10 m. The **TVR Y** device, powered directly by the instrument, displays the temperature measured by the **Pr1** probe using a 2 ½ digit display.

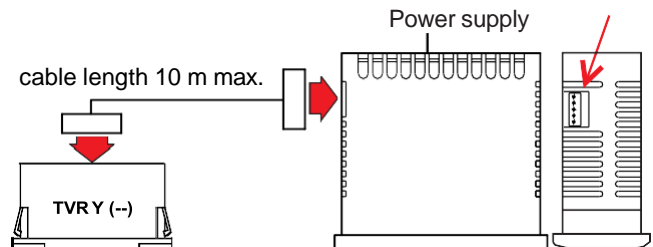

For more information see the user manual for the **TVR Y** device.

6.4 RS485 Serial Interface with ARS1

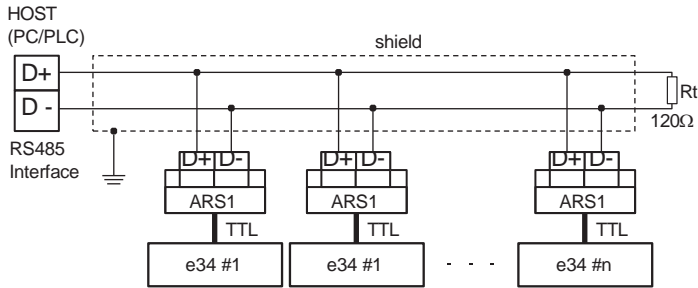

Through the **ARS1** device (TTL/RS485 interface) and the special TTL cable it is possible to connect the instrument to a RS485 serial communication network in which other instruments (controller or PLC) are inserted and typically referred to a Personal Computer used as a system supervisor.

Through the PC it is therefore possible to acquire all the operating data and to program all the configuration parameters of the instrument.

The software protocol adopted by the instrument is of the Modbus RTU type widely used in many PLC and supervision programs available on the market.

If the instrument is used in an RS485 network, program the station address to the τ_{AS} parameter.

The baud-rate of the serial port can not be set and is fixed at the value of 9600 baud.

The ARS1 converter is powered directly from the instrument.

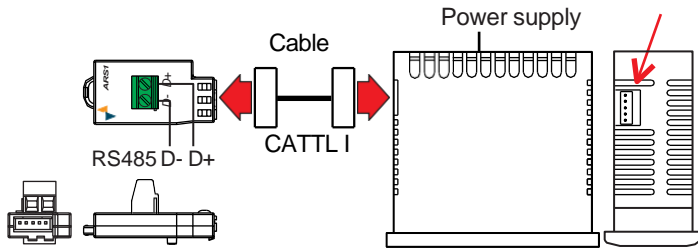





For more information, see the user manual for the **ARS1** device.

7. PROGRAMMABLE PARAMETERS TABLE

Here below is a description of all the parameters available on the instrument. Some of them may not be present, either due to the fact they depend on the type of instrument or because they are automatically disabled as unnecessary.

Parameter	Description	Range	Def.	Note
1	SPH Turbo Set Point (min. SP or Heating SP HC mode)	-99.9 ÷ SPE	-5.0	
2	SPE Eco Set Point	S.PH ÷ 999	10.0	
3	SP1 Set Point 1	SPH ÷ SPE	4.0	
4	SP2 Set Point 2	SPH ÷ SPE	2.0	
5	SP3 Set Point 3	SPH ÷ SPE	0.0	
6	iUP Unit of measurement and resolution (decimal point)	C0 °C, resolution 1°; F0 °F, resolution 1°; C1 °C, resolution 0.1°; F1 °F, resolution 0.1°.	C1	
7	iFt Measurement filter	oF Not used; 0.1 ÷ 20.0 s	2.0	
8	iC1 Pr1 Probe Calibration (temperature control)	-30.0 ÷ +30.0°C/°F	0.0	
9	iC2 Pr2 Probe Calibration	-30.0 ÷ +30.0°C/°F	0.0	
10	iC3 Pr3 Probe Calibration	-30.0 ÷ +30.0°C/°F	0.0	
11	iCU Display offset	-30.0 ÷ +30.0°C/°F	0.0	
12	iP2 Input Pr2 usage	oF Unused; EP Evaporator probe;	dG	
13	iP3 Input Pr3 usage	Au Auxiliary probe; dG Digital Input.	dG	
14	iFi Function and logic functioning of the Digital Input (adding the "-" minus sign the logic is inverted)	0 No function; 1 Open Door; 2 Open Door with Fan (Fn) Lock; 3 Open Door with Fan (Fn) and Output (ot) Lock; 4 External Alarm; 5 External alarm with control output disabling; 6 Normal/Eco select; 7 On/Stand by select; 8 Start a Turbo cycle.	2	
15	iti Digital Input Delay	oF Disabled; -1 ÷ -59 (s) ÷ 1 ÷ 99 (min).	oF	
16	iEt Eco Mode activation delay at Door closed	oF Disabled; -1 ÷ -59 (min) ÷ 1 ÷ 99 (h).	2	
17	itt Max. time functioning in Eco Mode	oF Disabled; -1 ÷ -59 (min) ÷ 1 ÷ 99 (h).	oF	
18	iDS Variable normally displayed	P1 Probe Pr1 measure; P2 Probe Pr2 measure; P3 Probe Pr3 measure; Ec Measure Pr1 in Normal mode, ECO label when in ECO mode; SP Active Set Point; oF Display not lit.	P1	
19	rd Differential (Hysteresis) in normal mode	0.0 ÷ 30.0°C/°F	2.0	
20	rEd Differential (Hysteresis) in ECO mode	0.0 ÷ 30.0°C/°F	4.0	
21	rHd Differential (Hysteresis) in Turbo mode or Heating in HC mode	0.0 ÷ 30.0°C/°F	2.0	
22	rt1 Output activation time for Pr1 probe error	oF Disabled; -1 ÷ -59 (s) 1 ÷ 99 (min).	oF	
23	rt2 Output deactivation time for Pr1 probe error	oF Disabled; -1 ÷ -59 (s) 1 ÷ 99 (min).	oF	
24	rHC Output(s) operating mode	H Heating; C Cooling; nr Neutral zone; HC Neutral Zone with independent Set Point; C3 Cooling with 3 automatic switch modes; H- Heating with symmetrical hysteresis; C- Cooling with symmetrical hysteresis.	C	
25	rtC Length of Turbo cycle	oF Function disabled; -1 ÷ -59 (min) 1 ÷ 99 (h).	1	
26	dtE Defrost stop temperature	-99.9 ÷ +999°C/°F	8.0	
27	dtS Defrost enable temperature	-99.9 ÷ +999°C/°F	2.0	
28	dtF Defrost start temperature	-99.9 ÷ +999°C/°F	-99.9	

Parameter	Description	Range	Def.	Note	
29	dSt	Delay start Defrost by dtF start temperature	oF Function disabled; -1 ÷ -59 (s) ÷ 1 ÷ 99 (min)	1	
30	ddL	Display Lock during defrost	oF Not active; on Active at last measure; Lb Active with label (dEF during defrost and PdF at defrost).	oF	
31	dcd	Defrost activation time for continuous compressor operating	oF Disabled; -1 ÷ -59 (min) ÷ 1 ÷ 99 (h)	oF	
32	dde	Max. defrost duration	oF Function disabled; -1 ÷ -59 (s) ÷ 1 ÷ 99 (min).	20	
33	ddp	Pre-defrost time length for dH output	oF Function disabled; -1 ÷ -59 (s) ÷ 1 ÷ 99 (min).	oF	
34	dPd	Post-defrost time length for dH output	oF Function disabled; -1 ÷ -59 (s) ÷ 1 ÷ 99 (min).	oF	
35	dtD	Compressor delay after defrost (drainage time)	oF Function disabled; -1 ÷ -59 (s) ÷ 1 ÷ 99 (min)	20	
36	ddt	Defrosting Type	EL Electrical heating/stop compressor; in Hot gas/reverse cycle; no Without compressor output conditioning; Et Electrical heating with evaporator temperature control.	EL	
37	ddC	Defrosting starting mode	rt Real time intervals; ct ot output on time intervals; cS Defrost every ot switching OFF (+ rt intervals); cL Do not use.	rt	
38	drS	First defrost count mode and ECO mode delay	oF dSd and iEt counts from instrument Power ON; 1 dSd defrost count after reaching Set (Pull down end); 2 ECO mode delay count for closed door iEt after Set Point reaching (Pull down end); 3 dSd defrost count and ECO mode delay for closed door iEt after reaching Set Point (Pull down end).		
39	ddi	Defrosting interval	oF Function disabled; -1 ÷ -59 (min) ÷ 1 ÷ 99 (h).	oF	
40	dSd	Delay first defrost after power-on	oF Defrost at power-on; -1 ÷ -59 (min) ÷ 1 ÷ 99 (h).	oF	
41	ddd	Dynamic Defrost Percentage reduction	0 ÷ 100%	0	
42	dEi	Defrosting interval for evaporator probe error	oF Function disabled; -1 ÷ -59 (min) ÷ 1 ÷ 99 (h)	6	
43	dEE	Length of defrost cycle for evaporator probe error	oF Function disabled; -1 ÷ -59 (s) ÷ 1 ÷ 99 (min).	10	
44	Ftn	Fan time activation with ot output (compressor) OFF	oF Function disabled; -1 ÷ -59 (s) ÷ 1 ÷ 99 (min).	5	
45	FtF	Fan time deactivation with ot output (compressor) OFF	oF Function disabled; -1 ÷ -59 (s) ÷ 1 ÷ 99 (min).	oF	
46	FFL	High temperature fan deactivation	- 99.9 ÷ 999 °C/°F	10.0	
47	FLF	Low temperature fan deactivation	- 99.9 ÷ 999°C/°F	-99.9	
48	FdF	Differential fan control	0.0 ÷ 30.0°C/°F	1.0	
49	FFE	Fan status during defrost	oF - on	oF	
50	FFd	Fan delay after defrost	oF Function disabled; -1 ÷ -59 (s) ÷ 1 ÷ 99 (min).	oF	
51	PP1	ot output delay at switching ON	oF Function disabled; -1 ÷ -59 (s) ÷ 1 ÷ 99 (min).	oF	
52	PP2	ot output delay after switching OFF	oF Function disabled; -1 ÷ -59 (s) ÷ 1 ÷ 99 (min).	oF	
53	PP3	Min. time between two ot output switching ON	oF Function disabled; -1 ÷ -59 (s) ÷ 1 ÷ 99 (min).	oF	
54	Pod	Outputs delay at power ON	oF Function disabled; -1 ÷ -59 (s) ÷ 1 ÷ 99 (min).	oF	
55	AAy	Temperature Alarm 1 type	1 Absolute for Pr1 with label Hi or Lo; 2 Relative to Pr1 with label Hi or Lo; 3 Absolute for Au with label Hi or Lo; 4 Relative to Au with label Hi or Lo; 5 Absolute for Pr1 with no label; 6 Relative to Pr1 with no label; 7 Absolute for Au with no label; 8 Relative to Au with no label.	1	

Parameter	Description	Range	Def.	Note
56	AHA High temperature Alarm threshold	oF Function disabled; -99.9 ÷ +999°C/°F.	oF	
57	ALA Low temperature Alarm threshold	oF Function disabled; -99.9 ÷ +999°C/°F	oF	
58	AAd Temperature Alarms Differential	0.0 ÷ 30.0°C/°F	1.0	
59	AAt Temperature Alarms Delay	oF Function disabled; -1 ÷ -59 (s) ÷ 1 ÷ 99 (min).	oF	
60	AtA Alarms memory	oF Alarm memory disabled; on Alarm memory enabled;	oF	
61	APA Temperature Alarms delay at power ON	oF Function disabled; -1 ÷ -59 (s) ÷ 1 ÷ 99 (min).	2	
62	AdA Temperature Alarms delay after defrost and unlock display delay after defrost	oF Function disabled; -1 ÷ -59 (min) ÷ 1 ÷ 99 (h).	1	
63	AoA Open Door Alarm Delay	oF Function disabled; -1 ÷ -59 (s) ÷ 1 ÷ 99 (min).	3	
64	oo1 OUT1 function	oF No function; ot Temperature control (compressor); dF Defroster control;	ot	
65	oo2 OUT2 function	Fn Fans; Au Auxiliary;	dF	
66	oo3 OUT3 function	At/t Silenceable alarm; AL/-L Not silenceable Alarm; An/-n Stored Alarm;	Fn	
67	oo4 OUT4 function	on ON when the instrument is ON; HE Heating (Neutral zone control); L1 Showcase light with ECO function (ON with SP, OFF with SPE); L2 Interior light (OFF with door closed, lit with door open); dH Pre and post defrost resistance output; -d Defroster control with inverse logic (negated dF output).	L1	
68	obu Buzzer function mode	oF Function disabled; 1 Active for alarms only; 2 Active for key pressed only; 3, 4 Active for alarms and key pressed.	3	
69	oFo Auxiliary output function	oF Function disabled; 1 Control output ot delayed; 2 Manual activation by key.	oF	
70	otu Time relative to auxiliary output	oF Function disabled; -1 ÷ -59 (s) ÷ 1 ÷ 99 (min).	oF	
71	tUF  Key Function	oF No function; 1 Eco Mode direct selection (+ turn OFF the showcase light, if configured); 2 Switch ON/Switch OFF (Stand-by) the controller.	1	
72	tFb  Key Function	oF No function; 1 Enable  key to control the light (L1 and Au with Fo = 2).	1	
73	tLo Keyboard lock function delay	oF Function disabled; -1 ÷ -59 (s) ÷ 1 ÷ 30 (min).	oF	
74	tEd Set Point change procedure	0 Disabled; 1 Active Set Point Direct change between limits SH ÷ SE; 2 Active Set Point Direct selection between SP1, SP2 and SP3 with  and  keys.	2	
75	tPP Password to Access Parameter set up	oF Function disabled; 001 ÷ 999.	oF	
76	tas Seroal Communications Address	0 ÷ 255.	1	
77	tdu Filter to suppress the display of increasing temperature variations lower than 0.1°	oF Function disabled; 0.1 ÷ 20.0 s	oF	
78	tdd Filter to suppress the display of decreasing temperature variations lower than 0.1°	oF Function disabled; 0.1 ÷ 20.0 s	oF	
79	ULU Low mains alarm	oF Function disabled; 9 ÷ 27 (V x 10).	oF	
80	UHU High Mains alarm	oF Function disabled; 9 ÷ 27 (V x 10).	oF	
81	U Ud Mains alarms delay	oF Function disabled; -01 ÷ -59 (s) ÷ 01 ÷ 99 (min)	oF	
82	UOU Mains Voltage calibration	-30 ÷ 30 V	0	

8. PROBLEMS AND MAINTENANCE

8.1 Notifications

8.1.1 Error messages

Error	Reason	Action
E1 -E1 E2 -E2 E3 -E3	The probe may be interrupted (E) or in short circuit (-E) or may measure a value outside the range allowed	Check the probe connection with the instrument and check that the probe works correctly
epr	Internal EEPROM memory error	Pressthe  key
err	Fatal memory error	Replace the instrument or ship to factory for repair

8.1.2 Other messages

Message	Reason
od	Delay at power-on in progress
Ln	Keyboard locked
Hi	Maximum temperature alarm in progress
Lo	Minimum temperature alarm in progress
AL	Digital Input alarm in progress
oP	Door Open
dEF	Defrost in progress with ddL = Lb
PdF	Post-defrosting in progress with ddL = Lb
Eco	Eco Mode in progress
trb	Turbo Mode in progress

8.2 Cleaning

We recommend cleaning of the instrument only with a slightly wet cloth using water and not abrasive cleaners or solvents.

8.3 Disposal

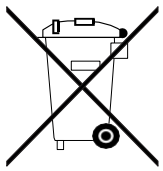

The appliance (or the product) must be disposed of separately in compliance with the local standards in force on waste disposal.

9. WARRANTY AND REPAIRS

The instrument is under warranty against manufacturing flaws or faulty material, that are found within 18 months from delivery date. The warranty is limited to repairs or to the replacement of the instrument.

The eventual opening of the housing, the violation of the instrument or the improper use and installation of the product will bring about the immediate withdrawal of the warranty effects.

In the event of a faulty instrument, either within the period of warranty, or further to its expiry, please contact our sales department to obtain authorisation for sending the instrument to our company.

The faulty product must be shipped to Ascon Technologic with a detailed description of the faults found, without any fees or charge for Ascon Technologic, except in the event of alternative agreements.

10. TECHNICAL DATA

10.1 Electrical characteristics

Power supply: 100 ÷ 240 VAC, 12 VAC/VDC ±10%;

AC frequency: 50/60 Hz;

Power consumption: About 4 VA;

Inputs: 3 inputs for temperature probes:

NTC (103AT-2, 10 k.Ω @ 25°C);

1 free of voltage digital input as an alternative to input probe Pr2 or Pr3;

Output: Up to 4 relay (or 2 relay and 2 SSR) outputs:

	EN 61810	EN 60730	UL 60730
Out1 (R) - SPST-NO - 16A - 1HP 250V, 1/2 HP 125 VAC	16 (9) A	10 (4) A	12 A Res., 30 LRA, 5 FLA
Out2, 3, 4 SPST-NO: 5A - 1/10 HP 125/250 V	5 (1) A	2 (1) A	2 A Gen. Use
Out2, 3 - SSR 2A/250 V	0.1 A (min.) 0.5A (max.)		

12 A max. for those with removable terminal model;

Relay output Electrical life: 100000 operations;

Action type: Type 1.C (EN 60730-1);

Overvoltage category: II;

Rated impulse voltage: 2500 V for 115/230 V; 500 V for 12-24 V;

Protection class: Class II;

Isolation: Reinforced insulation between the low voltage parts (power supply and relay output) and front panel; Reinforced insulation between the low voltage parts (power supply and relay output) and the extra low voltage section (inputs), No insulation between type F power supply and inputs.

10.2 Mechanical characteristics

Housing: Self-extinguishing plastic, UL 94 V0;

Ball Pressure Test as described in EN60730: accessible parts 75°C; support live parts 125°C;

Heat and fire resistance category: D;

Dimensions: 78 x 35 mm, depth 64 mm;

Weight: About 190 g;

Mounting: Incorporated flush in panel (thickness max. 12 mm) in a 71 x 29 mm hole;

Connections:

Inputs: fixed or removable screw terminal block for 0.2 ÷ 2.5 mm²/AWG 24 ÷ 14 cables;

Power supply and Outputs: fixed or removable screw terminal block or Faston 6.3 mm for 0.2 ÷ 2.5 mm²/AWG 24 ÷ 14 cables;

Protection degree: IP65 mounted with gasket and screw type bracket (both optional);

Pollution degree: 2;

Operating temperature: 0 ÷ 50°C;

Operating humidity: < 95 RH% with no condensation;

Storage temperature: -25 ÷ +60°C.

10.3 Functional features

Temperature Control: ON/OFF mode;

Defrost control: Interval cycles or by electric heating/hot-gas/ reverse cycle or by stopping the compressor;

Measurement range: NTC: -50 ÷ +109°C/-58 ÷ +228°F;

Display resolution: 1° or 0.1° (range -99.9 ÷ +99.9°);

Overall accuracy: ±(0.5% fs + 1 digit);

Sampling rate: 130 ms;

Display: 3 Digit Red or Blue (optional), height 17.7 mm;

Software class and structure: Class A;

Compliance: Directive 2014/108/CE (EN55022: class B;

EN61000-4-2: 8 kV air, 4 kV cont.; EN61000-4-3: 10 V/m;

EN61000-4-4: 2 kV supply and relay outputs, 1 kV inputs;

EN61000-4-5: supply 2 kV com. mode, 1 kV\diff. mode;

EN61000-4-6: 3V),

Directive 2006/95/CE (EN 60730-1, EN 60730-2-9),
Regulation 37/2005/CE (EN13485 air, S, A, 2, -50°C +90°C
with probe NTC 103AT11).

11. INSTRUMENT ORDERING CODE

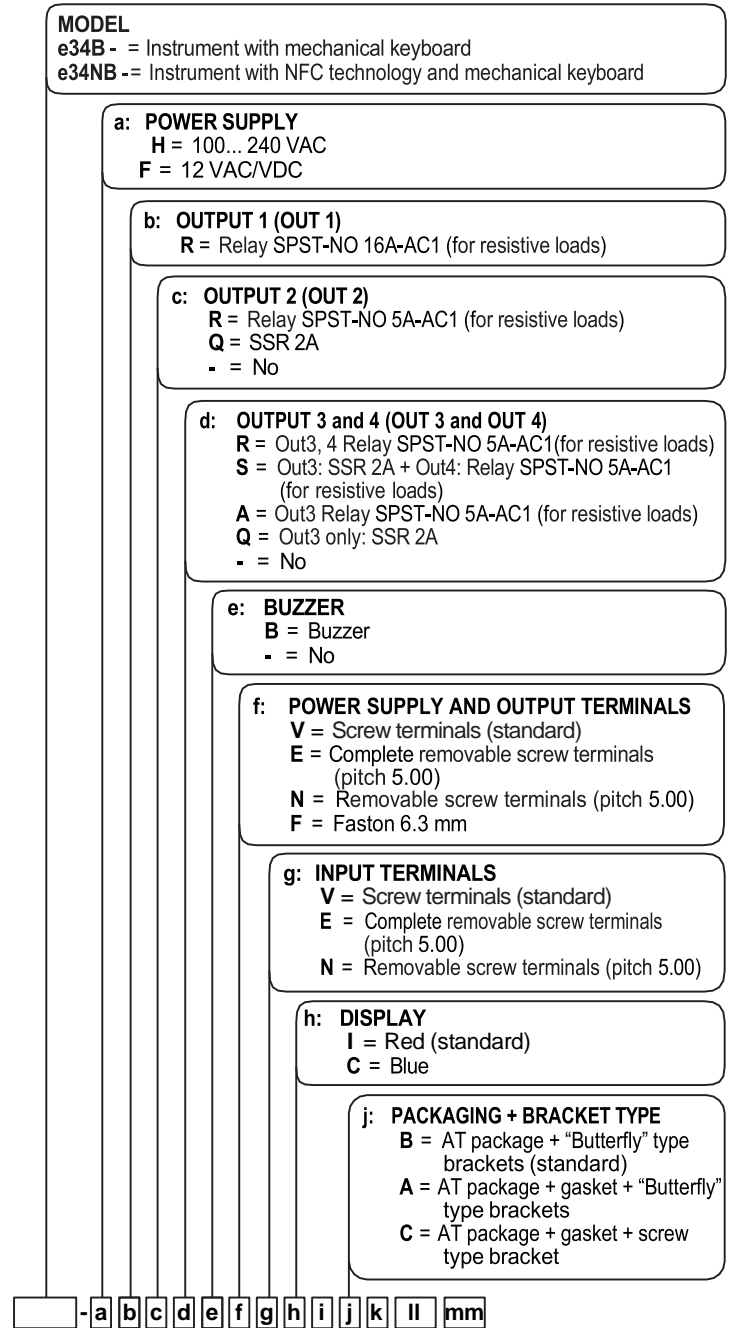

i, k: RESERVED CODES; II, mm: SPECIAL CODES